

VILLAGE OF PORT CHESTER
BOARD OF TRUSTEES

Meeting, MONDAY, JULY 16, 2012

6:30 P.M.

VILLAGE JUSTICE COURTROOM

350 North Main Street

Port Chester, New York

AGENDA

Amended 7/16/12

6:30 P.M.

I. MOTION FOR EXECUTIVE SESSION:

1. Consultation with Village Staff regarding law enforcement of places of entertainment.

7:00 P.M.

II. AFFIDAVIT OF PUBLICATION AND NOTICE OF PUBLICATION RE:

1. Public Hearing on the proposed Village of Port Chester Comprehensive Plan and the Zoning Amendments and Amendments to the Village Official Zoning Map Implementing the Comprehensive Plan.

III. PRESENTATIONS:

1. Use of Village property adjacent to downtown shoppers' parking lot.

IV. PUBLIC COMMENTS:

V. RESOLUTIONS:

Finance:

1. Accept donations from concerned citizens to replace and restore World War II plaques in Lyon Park.
2. Award contract for replacement of Bush Homestead roof to Bush Cabrera Home Improvement Inc., 105 Pearl Street, Port Chester, NY.

Police:

1. Budget amendment for use of DEA funds to purchase the following Police equipment:
 - a. Remote Access to Records Management System.
 - b. Taser Equipment.
 - c. Ballistic Vests.

Senior Nutrition Program:

1. Authorize The Port Chester Nutrition Program to enter into contract with Westchester County for the IIC-1 and IIC-2 Program Year January 1 – December 31, 2012 for the amount \$76,092 for IIC-1 and \$10,919 for IIC-2.

2. Authorize The Port Chester Nutrition Program to enter into contract with Westchester County for the IIIB Program Year January 1 – December 31, 2012 for the amount of \$17,245.
3. Authorize The Port Chester Nutrition Program to enter into contract with Westchester County for the Supplemental Nutrition and Assistance Program (SNAP) and Nutrition Services Incentive Program (NSIP) for program year 4/1/2012 through 3/31/2013.

Recreation:

1. Negative Declaration and authorize Village Manager to enter into an agreement with the Port Chester Soccer Club Inc. for fiscal year 2012-2013.

Village Clerk:

1. No objection to request by Capital Enterprises, Inc., d/b/a The Capital Theatre to the New York State Liquor Authority for substantial alteration to premises located at 149 Westchester Avenue.
2. Grant permission from Capital Enterprises, Inc., d/b/a The Capital Theatre to continue and expand the use of the existing sidewalk vault on the Broad Street frontage of the premises located at 149 Westchester Avenue.

VI. DISCUSSIONS:

1. March 2013 Election & Voter Education Program Coordinator (Bilingual).
2. Zoning and Code Enforcement Amnesty Workshop follow-up.
3. Sewer Rent Project status update.
4. Bulkhead follow-up.
5. Downtown Parking.
6. Starwood Capital workshop follow-up.
7. Property Maintenance.

VII. CORRESPONDENCE:

1. The Residents of Glendale Place are requesting permission for traffic and the following roads be blocked between the end of Glendale Place and Leicester Street as well as the end of Glendale Place and Clermont Avenue for a Block Party. The Block Party will be held on Saturday, July 21, 2012 from 2:00pm to 8:00pm.
2. Saint Peter's Episcopal Church is requesting permission for a procession of 50 to 70 people on Saturday, August 25, 2012 at 4:00pm to celebrate St. Mary the Virgin the Assumption. The procession will begin from 466 Westchester Avenue, cross over to Erving Street, then continue from South Avenue, North Avenue, Poningo Street, and then cross back to Westchester Avenue and enter the Church through Smith Street.
3. Centro Cultural Bolivian is requesting permission to place a banner across Westchester Avenue and Main Street to advertise the Bolivian Culture Parade to be held on Sunday, August 26, 2012.

4. The Port Chester Council of Community Services is requesting permission for the following items:
 - a. Provide the appropriate Police support to close Purdy Avenue between Grace Church Street and Don Bosco (8:00am – 6:30pm).
 - b. Police and Department of Public Works services.
 - c. Support from the Village Recreation Department of the day of the event.
 - d. Public toilets.
 - e. Showmobile, with generator.
 - f. Permission to fly banner over North Main Street and Westchester Avenue from July 18th to August 4th, announcing Port Chester Fest.

VIII. PUBLIC COMMENTS AND BOARD COMMENTS:

B/T Mtg. Date July 16, 2012	Action: <input type="checkbox"/> Adopted
Finance	<input type="checkbox"/> Defeated
Resolution # <u> 1 </u>	<input type="checkbox"/> Tabled
	<input type="checkbox"/> No Action
Motion 1 <u> </u> 2 <u> </u>	<input type="checkbox"/> Amended

RESOLUTION

DONATIONS TO REPLACE AND RESTORE WORLD WAR II PLAQUES IN LYON PARK

On motion of TRUSTEE _____, seconded by TRUSTEE _____, the following resolution was adopted by the Board of Trustees of the Village of Port Chester, New York:

WHEREAS, countless Village residents have laid their down their lives in the honor of this country; and

WHEREAS, in memorial to their ultimate sacrifice, plaques had been placed on trees in Lyon Park with the veteran's name, date and place of death, and

WHEREAS, over the years many of these plaques have went missing or are in state of disrepair; and

WHEREAS, correspondence has been received by Richard Cuddy dated June 27, 2012 whereby he and friends have proposed to donate funds to replace these plaques; and

WHEREAS, it is proposed that the Village provide assistance to this effort by having the Department of Public Works place all plaques in a cement base at the foot of the trees so as to rightfully preserve the memory of the fallen veterans, and

WHEREAS, the Park Commission has recommended this noble endeavor; and

WHEREAS, Board action is required to accept the generous donations of Richard Cuddy and friends of the Lyons Park Project on the conditions above-described. Now, therefore, be it

RESOLVED, that the Board of Trustees of the Village of Port Chester hereby accepts commends Richard Cuddy for his leadership role in honoring those residents who have fallen defending their country; and be it further

RESOLVED, that the Village Treasurer is authorized to accept and record said donations in the Trust/Agency Funds, Donation – World War 2 Plaques, line 3.3.76.

Vote:	Aye	Nay	Abstain	Absent
Brakewood				
Terenzi				
Didden				
Branca				
Kenner				
Marino				
Pilla				

Richard D. Cuddy, Sr.
58 Woodland Drive
Port Chester, New York 10573
(914) 937-1592
Westfair21@aol.com

Fellow Citizen,

Seventy years ago the world was engaged in a global war. The Village of Port Chester lost 90 residents. Village officials placed plaques on trees in Lyon Park with the deceased name, date and place of death.

Over the years 33 plaques have disappeared. We lost 29 plaques from WWII, one from Korea and 3 from The Vietnam Era. I would like to replace them, restore the existing ones and place them in cement at the base of the trees in the park.

The cost of a new plaque is \$225 and \$100 to refurbish an old one. The total cost is approximately \$15,000. Any additional funds will be used to gold leaf The Vietnam Memorial.

Make checks payable to: Village of Port Chester
Mail to: Village Clerk's Office
222 Grace Church Street
Port Chester, NY 10573

Please note: "Plaque" should be written on check. The deadline for donations is September 15, 2012.

Sincerely,

Vincent A. Lyons
Co-Chairman

Richard D. Cuddy, Sr.
Son of Major William Cuddy
killed on September 15, 1943

Memorial Plaques in Lyon Park

<u>Name</u>	<u>Branch of Svc</u>	<u>Date Died</u>	<u>Place of Death</u>
Pvt. Wallace Hains	U.S. Army	May 18, 1945	Okinawa
PFC George Grescak	U.S. Army	Sept. 29, 1944	Holland
Gunnery Mate George Kozlowski	U.S. Navy	Oct. 11, 1944	Philippines
1 st Lieut. Alphonsz Guardino	U.S. Air Force	March 25, 1945	Germany
PFC Frank Romzo	U.S. Army	Oct. 1, 1945	Norway
PFC Edward Pazona	U.S. Army	Jan. 9, 1945	France
PFC John McCann	U.S. Army	March 19, 1945	Germany
Seaman 1 st Class George Drummond	U.S. Navy	July 8, 1945	Corpus Christi, TX
Seaman 1 st Class Charles Marino	U.S. Navy	1945	South Pacific
PFC Firmino Tucci	U.S. Army	April 23, 1945	Germany
Sgt. Leonard Carriero	U.S. Army	April 14, 1945	England
Sgt. Francis Touri	U.S. Army	Dec. 8, 1944	France
PFC Frederick Halka	U.S. Army	Dec. 8, 1944	France
Pvt. James Murray	U.S. Army	Sept. 20, 1944	European Area
Pvt. John Morello	U.S. Army	July 12, 1944	U.S. Army
PFC Paul Astrolka	U.S. Army	Oct. 11, 1944	France
PFC Joseph Zikas	U.S. Army	July 1, 1944	Burma Area

PFC John Wasik	U.S. Army	Feb. 3, 1944	Italy
PFC Frank Douglas	U.S. Army	July 25, 1944	France
Pvt. Daniel Ruvo	U.S. Army	Sept. 16, 1943	Italy
Corp. John Emmeluth	U.S. Air Force	June 22, 1944	North Burma
Cpl. William Clifford	U.S.M.C.	July 24, 1944	Guam
2 nd Lieut. Joseph Bova	U.S. Air Force	June 19, 1944	France
PFC Alexander Rich	U.S. Army	Sept. 18, 1944	Italy
T/Sgt. Thomas Curtis	U.S. Air Force	Dec. 6, 1944	Italy
PFC Dominick Cikatelli	U.S. Army	Dec. 17, 1944	Germany
Pvt. Anthony Fallanca	U.S. Army	Dec. 21, 1944	Leyte Gulf
PFC Michael Ceruzzi	U.S. Army	Jan. 11, 1945	Belgium
PFC Edward Kasmarski	U.S. Army	May 27, 1943	El Paso, TX
Fireman Rudolph Quinn	U.S. Navy	Oct. 16, 1942	Solomon Island
Pvt. Rocco Tamucci	U.S. Army	July 25, 1943	Sicily
Pvt. Anthony Cotroneo	U.S.M.C.	Nov. 1, 1951	Korea
PFC Frank Howe	U.S.M.C.	Feb. 20, 1969	Viet Nam
PFC Terrence Cather	U.S. Army	Sept. 2, 1966	Viet Nam
Cpt. John Larkin	U.S.M.C.	Feb. 18, 1968	Viet Nam

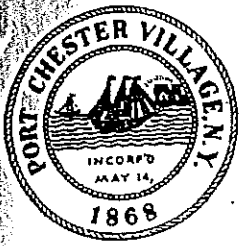

VILLAGE OF
PORT CHESTER

222 Grace Church Street, Port Chester, NY 10573

Office of the Village Clerk

(914) 939-5202
Fax: (914) 305-2560

June 27, 2012

Mayor Dennis Pilla & the Board of Trustees
Port Chester, New York

Dear Mayor Pilla & Board of Trustees:

The Park Commission at their meeting held on June 18, 2012, held a discussion regarding a request by Richard Cuddy to replace and restore the memorial plaques in Lyon Park which are dedicated to servicemen who gave their lives for our country.

Mr. Cuddy will remove the plaques that are nailed to the trees and cover the cost of replacing the missing plaques but asks the Board of Trustees for assistance in placing these plaques in a cement base at the foot of the trees.

The Park Commission recommends that the Mayor and Board agree to support Mr. Cuddy and this project and to absorb the cost of placing the plaques in the cement bases.

Very truly yours,

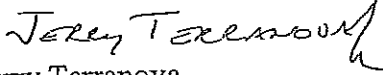
Jerry Terranova
Chairman, Park Commission

/vs

cc: Village Manager

B/T Mtg. Date July 16, 2012	Action: <input type="checkbox"/> Adopted
Finance	<input type="checkbox"/> Defeated
Resolution # <u> 2 </u>	<input type="checkbox"/> Tabled
	<input type="checkbox"/> No Action
Motion 1 <u> 2 </u>	<input type="checkbox"/> Amended

**RESOLUTION
REPLACEMENT OF ROOF AT BUSH HOMESTEAD**

On motion of TRUSTEE _____, seconded by TRUSTEE _____, the following resolution was adopted by the Board of Trustees of the Village of Port Chester, New York:

WHEREAS, the wood roof at the Bush Homestead is in urgent need of replacement; and

WHEREAS, the Village obtained technical assistance from the New York Historic Preservation Office (SHPO) for guidance as to this work; and

WHEREAS, the Village sought proposals from qualified roofing contractors; and

WHEREAS, Cabrera Home Improvement, Inc. submitted the lowest proposal in the amount of \$34,400; and

WHEREAS, the work will be done consistent with New York State guidelines for historical buildings; and

WHEREAS, the contractor's background and references are all favorable. Now, therefore, be it

RESOLVED, that the Village Manager is hereby authorized to enter into an agreement with Cabrera Home Improvement, Inc., 105 Pearl Street, Port Chester, for the replacement of the wood roof at the Bush Homestead, in the amount of \$34,400, payment to be made from Capital Fund – project, Police & Village Owed Building Improvement a/c 5.1620.400.2007.0068.

Vote:	Aye	Nay	Abstain	Absent
Brakewood				
Terenzi				
Didden				
Branca				
Kenner				
Marino				
Pilla				

CABRERA HOME IMPROVEMENT INC

105 Pearl St

Port Chester NY 10573

914-9395978

914-4242107

Licensed and Insured NY & Connecticut

VILLAGE OF PORT CHESTER

Office # 914-9395206

05/21/2012

222 GRACE CHURCH STREET

Attention: Mr. Rocky Morabito Cell # 914-7748213

PORT CHESTER NY 10573

(NEW WOOD SHINGLE ROOF)

JOB LOCATION: 479 KING STRRET PORT CHESTER NY 10573 (BUSH HOMESTEAD HOUSE)

The following specification is submitted for your approval for work to be performed at the above location. The work will be performed as follows;

>Remove all existing wood shingles off complete roof down to rafters of complete hip roof of the house.

>Install Ice & Water Shield 3' at base around the roof, 12" along sides of the roof, along valleys around vent pipes, around chimneys.

> Install new copper drip edging around the roof, copper valleys & copper roof boots around vent pipes.

>Install new perfection wood shingles on complete roof of the house. (20years warranty)

>Install new roll vent at main ridge for best air circulation of the roof.

>Install new perfection wood hips at all ridges of the house.

>Install new copper step flashings around chimneys.

>Install new copper flashing around chimneys.>Village of Port Chester will supply dumpsters at job site.

>Contractor will remove all debris.

TOTAL COST \$ 34,400.00

PAYMENTS: 50% Deposit at contract signing. \$ 17,200.00

five years workmanship

Balance at day of completion. \$ 17,200.00

Warranty at all labor

Accepted & Agreed

Accepted & Agreed

By _____

By *Diego Cabrera*

Village Of Port Chester Officer

Contractor

Leave all existing copper gutters around the house and front copper lower roof of the house, replace any freeze and fascia board if is necessary around the house.

CABNERA HOME IMPROVEMENT INC

105 Pearl St

Port Chester NY 10573

914-9395978

914-4242107

Licensed and Insured NY & Connecticut

VILLAGE OF PORT CHESTER

Office # 914-9395206

05/21/2012

222 GRACE CHURCH STREET

Attention: Mr. Rocky Morabito Cell # 914-7748213

PORT CHESTER NY 10573

(REPOINT EXISTING CHIMNEYS)

JOB LOCATION: 479 KING STRETT PORT CHESTER NY 10573 (BUSH HOMESTEAD HOUSE)

The following specification is submitted for your approval for work to be performed at the above location. The work will be performed as follows;

- >Install metal scaffolding around chimneys to create safe working area.
- > Remove all existing cement joints off complete two chimneys of the house.
- > Clean all existing bricks of the two chimneys, using Iron brushes and graining to remove all debris from bricks.
- >Renew all cement joints of the two chimneys, using regular cement mortar.
- >Water proof chimneys, using special liquid silicone sealer.
- >Install new custom flew metal liner (Stainless) on one chimney of the house.
- >Install two new Stainless chimney caps.
- >Contractor will remove all debris.

TOTAL COST \$ 14,000.00

PAYMENTS: 50% Deposit at contract signing. \$ 7,000.00

Balance at day of completion. \$ 7,000.00

Accepted & Agreed

By _____

Village Of Port Chester Officer

five years workmanship

Warranty at all labor

Accepted & Agreed

BY Luigi Cabnera

Contractor

CARRERA HOME IMPROVEMENT INC

105 Pearl St

Port Chester NY 10573

914-9395978

914-4242107

Licensed and Insured NY & Connecticut

VILLAGE OF PORT CHESTER

Office # 914-9395206

05/21/2012

222 GRACE CHURCH STREET

Attention: Mr. Rocky Morabito Cell # 914-7748213

PORT CHESTER NY 10573

(NEW BRICK CHIMNEYS)

JOB LOCATION: 479 KING STRRET PORT CHESTER NY 10573 (BUSH HOMESTEAD HOUSE)

The following specification is submitted for your approval for work to be performed at the above location. The work will be performed as follows;

- >Install metal scaffolding around chimneys to create safe working area.
- > Remove all existing bricks off the chimneys down to level of the roof only.
- > Bulld new chimneys same dimensions as existing from level of the roof up, using old fashion bricks and cement mortar.
- >Install new clay flew pipes on each chimney.
- >Water proof chimneys, using special liquid silicone sealer.
- >Install two new Stainless chimney caps.
- >Village of Port Chester will supply dumpsters at job site.
- >Contractor will remove all debris.

TOTAL COST \$ 18,000.00

PAYMENTS: 50% Deposit at contract signing. \$ 9,000.00

Balance at day of completion. \$ 9,000.00

Accepted & Agreed

By _____

Village Of Port Chester Officer

five years workmanship

Warranty at all labor

Accepted & Agreed

By *Luis Carrera*

Contractor

B/T Mtg. Date July 16, 2012	Action: <input type="checkbox"/> Adopted
Police	<input type="checkbox"/> Defeated
Resolution # <u>1a</u>	<input type="checkbox"/> Tabled
	<input type="checkbox"/> No Action
Motion 1 <u>2</u>	<input type="checkbox"/> Amended

RESOLUTION
BUDGET AMENDMENT – DEA FUNDS
REMOTE ACCESS TO RECORDS MANAGEMENT SYSTEM

On motion of TRUSTEE _____, seconded by TRUSTEE _____, the following resolution was adopted by the Board of Trustees of the Village of Port Chester, New York:

WHEREAS, the Police Chief recommends the use of DEA Funds to purchase additional software for remote report writing capabilities for six (6) marked patrol vehicles for a total cost of \$9096.03. The breakdown is as follows: \$7000 from vendor Steamboat Data Systems, Inc., 20 Paddlewheel Court, Waterford, NY 12188 for software and licensing; \$1096.03 for purchase of Dell computer to add additional capabilities to current system from New York State contract number 83AEA; and \$1000 for IT installation from contracted IT company Dyntek. Now, therefore be it

RESOLVED, that the Board of Trustees of the Village of Port Chester, New York hereby authorizes the Village Treasurer to modify the 2012-13 General Fund Budget as follows:

GENERAL FUND		
Balance Sheet:		
001-001-0695	Deferred Revenue DEA	\$(9,096.03)
Revenues:		
001-0001-2613	Use of Deferred DEA Funds	\$9,096.03
Appropriations:		
001-3120-0200	Police Equipment	\$8,096.03
Appropriations:		
001-3120-0411	Computer Services	\$1,000.00

Vote:	Aye	Nay	Abstain	Absent
Brakewood				
Terenzi				
Didden				
Branca				
Kenner				
Marino				
Pilla				

B/T Mtg. Date July 16, 2012	Action: <input type="checkbox"/> Adopted
Police	<input type="checkbox"/> Defeated
Resolution # <u> 1b </u>	<input type="checkbox"/> Tabled
	<input type="checkbox"/> No Action
Motion 1 <u> 2 </u>	<input type="checkbox"/> Amended

RESOLUTION
BUDGET AMENDMENT – DEA FUNDS
TASER EQUIPMENT

On motion of TRUSTEE _____, seconded by TRUSTEE _____, the following resolution was adopted by the Board of Trustees of the Village of Port Chester, New York:

WHEREAS, the Police Chief recommends the use of DEA Funds to purchase three (3) new Taser model X26 weapons to replace the existing due to exceeded service life from vendor Taser, 17800 North 85th Street, Scottsdale, AZ, 85255-9603 for a total cost of \$2,421. Now, therefore be it

RESOLVED, that the Board of Trustees of the Village of Port Chester, New York hereby authorizes the Village Treasurer to modify the 2012-13 General Fund Budget as follows:

GENERAL FUND

Balance Sheet:

001-001-0695	Deferred Revenue DEA	\$(2,421.00)
--------------	----------------------	--------------

Revenues:

001-0001-2613	Use of Deferred DEA Funds	\$2,421.00
---------------	---------------------------	------------

Appropriations:

001-3120-0200	Police Equipment	\$2,421.00
---------------	------------------	------------

Vote:	Aye	Nay	Abstain	Absent
Brakewood				
Terenzi				
Didden				
Branca				
Kenner				
Marino				
Pilla				

B/T Mtg. Date July 16, 2012	Action: <input type="checkbox"/> Adopted
Police	<input type="checkbox"/> Defeated
Resolution # <u>1c</u>	<input type="checkbox"/> Tabled
	<input type="checkbox"/> No Action
Motion 1 <u>2</u>	<input type="checkbox"/> Amended

**RESOLUTION
BUDGET AMENDMENT – DEA FUNDS
BALLISTIC VESTS**

On motion of TRUSTEE _____, seconded by TRUSTEE _____, the following resolution was adopted by the Board of Trustees of the Village of Port Chester, New York:

WHEREAS, twelve (12) of the Police Department ballistic vests assigned to individual officers have reached or exceeded the five (5) year recommended service life, and the total replacement cost is \$6,916.44, and

WHEREAS the Police Chief recommends that DEA Funds be used to purchase six (6), \$3,458.22 of the twelve (12) new ballistic vests from NYS vendor, contract number PC64783, Buckshollow Emergency Equipment Corp., 15 Secor Road, Mahopac, NY 10541, for a total cost of \$6,916.44, the remaining 50% is already budgeted in FY 2012-13 Police Department, General Fund . Now, therefore be it

RESOLVED, that the Board of Trustees of the Village of Port Chester, New York hereby authorizes the Village Treasurer to modify the 2012-13 General Fund Budget as follows:

GENERAL FUND		
Balance Sheet:		
001-001-0695	Deferred Revenue DEA	\$(3,458.22)
Revenues:		
001-0001-2613	Use of Deferred DEA Funds	\$3,458.22
Appropriations:		
001-3120-0200	Police Equipment	\$3,458.22

Vote:	Aye	Nay	Abstain	Absent
Brakewood				
Terenzi				
Didden				
Branca				
Kenner				
Marino				
Pilla				

B/T Mtg. Date July 16, 2012	Action: <input type="checkbox"/> Adopted
Senior Nutrition	<input type="checkbox"/> Defeated
Resolution # <u> 1 </u>	<input type="checkbox"/> Tabled
Motion 1 <u> </u> 2 <u> </u>	<input type="checkbox"/> No Action
	<input type="checkbox"/> Amended

RESOLUTION

On motion of TRUSTEE, seconded by TRUSTEE, the
 following resolution was adopted by the Board of Trustees of the Village of Port Chester,
 New York:

RESOLVED, that the Village Manager be and is authorized to enter into an agreement with the County of Westchester for Title III-B, of the Older Americans Act and New York State Community Services for the Elderly Act, New York State to cover the programs provided by the Village of Port Chester for period covered January 1, 2012 through December 31, 2012.

Vote:	Aye	Nay	Abstain	Absent
Brakewood				
Terenzi				
Didden				
Branca				
Kenner				
Marino				
Pilla				



Robert P. Astorino, Westchester County Executive
Mae Carpenter, Commissioner
Department of Senior Programs and Services

June 11, 2012

Christopher Russo
Village Manager
Village of Port Chester
222 Grace Church St.
Port Chester, NY 10573

Dear Mr. Russo:

Enclosed is one blank copy of the Title IIIB contract to cover the programs to be provided by the Village of Port Chester for the program year 1/1/2012 through 12/31/2012. The contract is comprised of the following documents:

one (1) Agreement
one (1) Schedule A and
one (1) Schedule B

Please complete these documents as follows:

AGREEMENT:

Fill in all relevant information in the spaces provided on pages 1, 2, 11, the Contractor's Acknowledgement and the Certificate of Authority and make a copy. Make sure that where signatures are required on both copies that they are original and in **BLUE INK** only. **Return two (2) originally signed agreements.**

SCHEDULE A:

Fill in the relevant information on each page then make a copy. Make sure that where signatures are required on both copies that they are original and in **BLUE INK** only. **Return two (2) originally signed Schedule As.**

SCHEDULE B:

Fill in the relevant information on each page, making sure that where signatures are required that they are original and in **(BLUE INK)** only. **Please note that there have been revisions made to the Schedule B this year** to begin advance preparation for the Unit Cost Reimbursement system in 2013. Your program liaison should be contacted for questions relating to these revisions. **Return one (1) originally signed Schedule B.**

NOTE: You must use the original Agreements and Schedules that we have provided.
Scanned copies will be returned.

Tentative Funding for the Village of Port Chester for the current Title III-B program year, 2012, will be as follows:

Grant	Federal Funds	Local Match	County Match
Title III-B	\$17,245.00	\$11,983.00	N/A

Please be aware that the Department may reduce the amount payable to its contractors if the New York State Office for the Aging reduces the Department's Federal and/or State funding, in which case you will be notified around June 1, 2012.

We are currently requiring most contractors to complete a monthly electronic report in SAMS and to mail in a paper copy of the report to the program liaison. The completed SAMS MONTHLY ELECTRONIC PAPER REPORT and/or other approved reporting measure must be signed by the staff member responsible for the report. Reports should be received by the program liaison no later than the tenth (10th) day of the following month. Contractors that are not required to enter their data electronically into SAMS have already been informed.

Return two (2) originally signed contracts to me at the address on the footer of the first page. Please pay special attention to the **"Standard Insurance Provisions"** on pages 3 and 4 of the Schedule A for detailed information regarding ALL required insurances. Contracts will be on hold pending receipt of any missing insurance form. Remember to list **Westchester County as an Additional Insured** on the Certificate of Liability Insurance.

Please direct program-related questions to your program liaison Meleita Jones at 914-813-6420. You may also contact me at 914-813-6058 or via e-mail at ssj3@westchestergov.com for questions pertaining to the processing of the contract.

Sincerely,

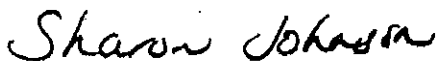

Sharon Johnson
Program Administrator

Encl.

B/T Mtg. Date July 16, 2012		Action: <input type="checkbox"/> Adopted
Senior Nutrition		<input type="checkbox"/> Defeated
Resolution # <u> 2 </u>		<input type="checkbox"/> Tabled
		<input type="checkbox"/> No Action
Motion 1 <u> 2 </u>		<input type="checkbox"/> Amended

RESOLUTION

On motion of TRUSTEE, seconded by TRUSTEE, the
following resolution was adopted by the Board of Trustees of the Village of Port Chester,
New York:

RESOLVED, that the Village Manager be and is authorized to enter into an agreement with the County of Westchester for Title III-C1, III-C2, and Nutrition Services Incentive Program (NSIP) of the Older Americans Act and New York State Community Services for the Elderly Act, New York State to cover the programs provided by the Village of Port Chester for period covered January 1, 2012 through December 31, 2012.

Vote:	Aye	Nay	Abstain	Absent
Brakewood				
Terenzi				
Didden				
Branca				
Kenner				
Marino				
Pilla				



Robert P. Astorino, Westchester County Executive

Mae Carpenter, Commissioner
Department of Senior Programs and Services

June 27, 2012

Carol Nielsen
Nutrition Program Director
Village of Port Chester
222 Grace Church St.
Port Chester, NY 10573

Dear Ms. Nielsen,

Enclosed is one blank copy of the III-C contract to cover programs to be provided by the Village of Port Chester for the Title III-C1, III-C2, and NSIP program year – 1/1/2012 through 12/31/2012. The contract is comprised of the following documents.

- one (1) Title III-C1, III-C2, and NSIP Agreement,
- one (1) Schedule A,
- one (1) Schedule C and
- one (1) Contractual contact information form

In order to streamline the contractual process to award the Nutrition Services Incentive Program (NSIP) funding, the Department is now requiring that NSIP funding be included in the III-C agreement. **Please be aware that the NSIP funding listed on the allocation are high estimates to cover your program for the projected annual NSIP allocation**

Please complete these documents as follows:

AGREEMENT:

Fill in all relevant information in the spaces provided on pages 1, 2, 11, the Contractor's Acknowledgement and the Certificate of Authority and make a copy. Make sure that where signatures are required on both copies that they are original and in BLUE INK only. **Return two (2) originally signed agreements.**

SCHEDULE A:

Fill in the relevant information on each page then make a copy. Make sure that where signatures are required on both copies that they are original and in BLUE INK only. **Return two (2) originally signed Schedule As.**

SCHEDULE C:

Fill in the relevant information on each page, making sure that where signatures are required that they are original and in (BLUE INK) only. **Return one (1) originally signed Schedule C.**

NOTE: You must use the original Agreements and Schedules that we have provided. Scanned copies will be returned.

Funding for the Village of Port Chester for the current Title III-C1, III-C2, and NSIP program year, will be as follows:

PROGRAM	FEDERAL FUNDS	LOCAL MATCH
III-C-1	\$52,278	\$19,336
Estimated III-C1 NSIP	\$23,814	N/A
III-C-2	\$8,637	\$3,195
Estimated III-C2 NSIP	\$2,282	N/A

Please be aware that the Department may reduce the amount payable to its contractors if the New York State Office for the Aging reduces the Department's Federal and/or State funding, in which case you will be notified.

For the contract year, all Nutrition Program subcontractors are required to mail in the completed SAMS MONTHLY NUTRITION REPORT signed by the staff member responsible for the report. The reports should be received by the County no later than the tenth (10th) day of the following month. **The County reserves the right to withhold payment to Contractor for its failure to submit the monthly report by the deadline, until the monthly report is received by the County.**

Return two (2) originally signed contracts to me at the address on the footer of the first page. Please pay special attention to the **"Standard Insurance Provisions"** on pages 3 and 4 of the **Schedule A** for detailed information regarding ALL required insurances. Contracts will be on hold pending receipt of any missing insurance form. Remember to list **Westchester County as an Additional Insured** on the Certificate of Liability Insurance.

Please direct program-related questions to your program liaison Ann Darcy at 914-813-6426. You may also contact me at 914-813-6058 or via e-mail at ssj3@westchestergov.com for questions pertaining to the processing of the contract.

Sincerely,



Sharon Johnson
Program Administrator
Encl.

B/T Mtg. Date **July 16, 2012**
Senior Nutrition

Resolution # 3

Motion 1 2

- Action: Adopted
 Defeated
 Tabled
 No Action
 Amended

RESOLUTION

On motion of TRUSTEE, seconded by TRUSTEE, the
following resolution was adopted by the Board of Trustees of the Village of Port Chester,
New York:

RESOLVED, that the Village Manager be and is authorized to enter into an agreement with the County of Westchester for Title III-B, III-C of the Older Americans Act and New York State Community Services for the Elderly Act, New York State Supplemental Nutrition Assistance Program (SNAP) and Nutrition Services Incentive Program (NSIP) for the period covered April 1, 2012 through March 31, 2013.

Vote:	Aye	Nay	Abstain	Absent
Brakewood				
Terenzi				
Didden				
Branca				
Kenner				
Marino				
Pilla				



Robert P. Astorino, Westchester County Executive

Mae Carpenter, Commissioner
Department of Senior Programs and Services

July 03, 2012

Carol Nielsen
Nutrition Program Director
Village of Port Chester
222 Grace Church St.
Port Chester, NY 10573

Dear Mr. Nielsen:

Enclosed is one blank copy of the Supplemental Nutrition and Assistance Program (SNAP) and Nutrition Services Incentive Program (NSIP) contract to cover programs to be provided by the Village of Port Chester for the SNAP and NSIP program year 4/1/2012 through 03/31/2013. The contract is comprised of the following documents:

one (1) SNAP and NSIP Agreement,
one (1) Schedule A and
one (1) Schedule B

Please be aware that the projected NSIP funding listed on the allocation chart is a high estimate to cover your program. Please use 2011 NSIP awards as a guide for your municipal budgets.

The contract should be completed as follows:

AGREEMENT:

Fill in all relevant information in the spaces provided on pages 1, 2, 11, the Contractor's Acknowledgement and the Certificate of Authority and make a copy. Make sure that where signatures are required on both copies that they are original and in **BLUE INK** only. **Return two (2) originally signed agreements.**

SCHEDULE A:

Fill in the relevant information on each page, then make one (1) copy making sure to put original signatures in **BLUE INK** only where required on each of the copies. **Return two copies with original signatures.**

SCHEDULE B:

Complete the enclosed Schedule B and return one copy with original signatures in BLUE INK only. The SNAP budget, which is part of Schedule B, must be completed and submitted in its entirety.

NOTE: You must use the original Agreements and Schedules that we have provided. Scanned or retyped copies will be returned.

Funding for the Village of Port Chester for the current SNAP and NSIP program year, 2012 - 2013, will be as follows:

SNAP FUNDS	ESTIMATED SNAP NSIP
\$32,614.00	\$13,563.00

For the 2012-2013 contract year, all Nutrition Program subcontractors are required to mail in the completed SAMS MONTHLY NUTRITION REPORT signed by the staff member responsible for the report. The reports should be received by the County no later than the tenth (10th) day of the following month. **The County reserves the right to withhold payment to Contractor for its failure to submit the monthly report by the deadline, until the monthly report is received by the County.**

Return two (2) originally signed contracts to me at the address on the footer of the first page. Please pay special attention to the **"Standard Insurance Provisions" on pages 3 and 4 of the Schedule A** for detailed information regarding ALL required insurances. Contracts will be on hold pending receipt of any missing insurance form. Remember to list **Westchester County as an Additional Insured** on the Certificate of Liability Insurance.

Please direct program-related questions to your program liaison Ann Darcy at 914-813- 6426. You may also contact me at 914-813-6058 or via e-mail at ssj3@westchestergov.com for questions pertaining to the processing of the contract.

Sincerely,



Sharon Johnson
Program Administrator

Encl.

B/T Mtg. Date July 16, 2012	Action: <input type="checkbox"/> Adopted
Recreation	<input type="checkbox"/> Defeated
Resolution # <u>1a</u>	<input type="checkbox"/> Tabled
	<input type="checkbox"/> No Action
Motion 1 <u>2</u>	<input type="checkbox"/> Amended

**SEQR DETERMINATION OF SIGNIFICANCE
NEGATIVE DECLARATION
RESOLUTION OF THE VILLAGE OF PORT CHESTER
BOARD OF TRUSTEES**

July 13, 2012

License agreement between the Village of Port Chester and the Port Chester Soccer Club, Inc. to administer the Village's recreation soccer program at Columbus Park.
Section 142.47 Block 1 Lot 34

WHEREAS, the Village of Port Chester Board of Trustees ("Village") seeks to enter into a formal public-private license agreement with the not-for-profit Port Chester Soccer Club, Inc. ("Club") to administer the Village Recreation Department's Soccer Program ("Program").

WHEREAS, the agreement states that the Club will solely and exclusively undertake all aspects of the program, including youth and adult soccer, for a period of one year commencing on July 18, 2012 and ending on July 18, 2013 at Columbus Park, more specifically known and designated as Section 142.47 Block 1, Lot 34; and

WHEREAS, the project is defined as an Unlisted Action; and

NOW THEREFORE BE IT RESOLVED, that pursuant to Part 617 of the SEQR Regulations, the Village of Port Chester Board of Trustees hereby designates itself as the Lead Agency for the SEQR Review of this Unlisted Action, and in this capacity will conduct an Uncoordinated Review.

BE IT FURTHER RESOLVED, that pursuant to Part 617 of the implementing regulations pertaining to Article 8 (State Environmental Quality Review Act) of the Environmental Conservation Law, the Lead Agency has determined that the proposed Unlisted Action will not have a significant effect on the environment for the reasons enumerated in the attached Negative Declaration Form.

On the motion of TRUSTEE _____, seconded by TRUSTEE _____, it was adopted by the following vote:

Vote:	Aye	Nay	Abstain	Absent
Brakewood				
Terenzi				
Didden				
Branca				
Kenner				
Marino				
Pilla				

617.21
Appendix F
State Environmental Quality Review
NEGATIVE DECLARATION
Notice of Determination of Non-Significance

Project Number _____

Date July 13, 2012

This notice is issued pursuant to Part 617 of the implementing regulations pertaining to Article 8 (State Environmental Quality Review Act) of the Environmental Conservation Law.

The Village of Port Chester Board of Trustees as lead agency has determined that the proposed action described below will not have a significant effect on the environmental and a Draft Environmental Impact Statement will not be prepared.

Name of Action:

Licensing agreement between the Village of Port Chester ("Village") and the Port Chester Soccer Club, Inc. ("Club") to administer the Village's recreation soccer program.

SEQR Status:Type I Unlisted **Conditioned Negative Declaration:**Yes No **Description of Action:**

Public-private partnership agreement between the Village of Port Chester and the not-for-profit Port Chester Soccer Club, Inc. to solely and exclusively undertake to operate all aspects of the Village Recreation Department's Soccer Program, including youth and adult soccer, for the period of one year commencing on July 18, 2012 and ending on July 18, 2013.

The agreement will grant a non-exclusive, revocable license to the Club for the use of the soccer facility at Columbus Park during regular business hours of the Village. Additional such use shall be permitted on the weekdays until 8:30 p.m. and on weekends from 9:00 a.m. to 8:30 p.m. during the fall season (September 1 through November 30) and spring season (March 15 through May 30).

Approximate enrolment in the club is as follows:

Recreation Soccer Program: approximate 120 -130

Travel Soccer Program: approximate 300

Adult League Program: approximate 90 - 100

Location: Columbus Park, Port Chester, Westchester County(Section 142.47 Block 1 Lot 34)

REASONS SUPPORTING THIS DETERMINATION:

No physical modifications are proposed to the site as part of this agreement that would adversely affect the environmental characteristics of Columbus Park with respect to stormwater management, erosion and sediment control, wetland resources, or removal of existing vegetation. Further, the project is not located within either a 100 or 500 year floodplain as designated by FEMA.

The scheduled use of the soccer field for youth and adult leagues will be distributed among weekdays and weekends in such a manner that would not materially affect the operation of the facility beyond typical recreation use.

The hours of operation are as follows:

Fall - September, October, November

Weekdays from 4:45pm – Dusk, hours extended to 8:30pm with portable flood lights

Weekends are from 9pm-6pm hours extended to 8:30pm when necessary

Winter - December, January, February

Some play allowed based on weather conditions

Spring - March, April, May, June

Weekdays from 4:45pm – Dusk, hours extended to 8:30pm with portable flood lights

Weekends are from 9pm-6pm hours extended to 8:30pm when necessary

Summer- July, August

Weekdays 4:45 pm - Dusk

Weekends 9am - Dusk

Further, the proposed action does not create a material conflict with the community's current recreation plans or goals.

Potential impacts relating to the proposed action include the following:

1. The agreement includes the permitted use of portable lighting at the facility to be used after dusk during the fall and spring soccer season. Artificial light created during this period will have a negligible effect on the overall ambient condition in surrounding neighborhoods and Interstate 95. No adverse visual impacts are anticipated.
2. The use of the facility delineated in the agreement can be accommodated by the facility's and surrounding area's existing transportation infrastructure network. Games are played over two hour period without overlap, thus generating minimal periods of peak traffic and parking demand before and after events. The traffic generated by the project will not result in significant traffic impacts in excess of typical use of the existing facility and the surrounding roadway network will continue to operate at a satisfactory Levels of Service (LOS) during peak periods. No adverse traffic impacts are anticipated.
3. Potential noise associated with normal recreational use of the soccer field during specified hours will not result in a significant adverse environmental impact to the surrounding community.
4. The increase in solid waste and sewer loads generated by the use of the facility will be minimal and are well within existing capacity. No adverse impacts are anticipated.
5. The action would not result in changes in two or more elements of the environment which alone would not have a significant effect on the environment, but when considered together, would result in a substantial adverse impact on the environment.
6. The action is not related to another action which would be funded or approved by an agency which, when considered cumulatively, would meet one or any of the aforementioned criteria.

If Conditioned Negative Declaration, provide on attachment the specific mitigation measures imposed.

For Further Information:

Contact Person: Chris Russo, Village Manager
Address: 222 Grace Church Street, Port Chester, NY 10573
Telephone Number: 914-939-2200

For Type I Actions and Conditioned Negative declarations, a Copy of the Notice sent to:

Commissioner, Dep't of Environmental Conservation, 625 Broadway, Albany, NY 12233
NYSDEC Region 3, 21 South Putt Corners Road, New Paltz, NY 12561
Mayor, Village of Port Chester, 222 Grace Church Street, Port Chester, NY 10573

B/T Mtg. Date July 16, 2012		Action: <input type="checkbox"/> Adopted	
Recreation		<input type="checkbox"/> Defeated	
Resolution # <u> 1b </u>		<input type="checkbox"/> Tabled	
	Motion 1 <u> </u> 2 <u> </u>	<input type="checkbox"/> No Action	
		<input type="checkbox"/> Amended	

RESOLUTION

AGREEMENT WITH
PORT CHESTER SOCCER CLUB INC.

On motion of TRUSTEE _____, seconded by TRUSTEE _____, the following resolution was adopted by the Board of Trustees of the Village of Port Chester, New York:

RESOLVED, that the Village Manager be authorized to enter into an agreement with Port Chester Soccer Club Inc., 22 Soundview Street, Port Chester, New York 10573 for the Village's Recreation Department Soccer Program for fiscal year 2012-2013 in the amount of \$31,000.

Vote:	Aye	Nay	Abstain	Absent
Brakewood				
Terenzi				
Didden				
Branca				
Kenner				
Marino				
Pilla				

MEMORANDUM

TO: Christopher J. Russo
Village Manager

FROM: Heather Krakowski 
Recreation Leader

SUBJECT: Soccer League –Performance Review 2011-2012

DATE: July 13, 2012

The Port Chester Soccer Club provides soccer programming for all ages, Fall, Winter, Spring and Summer. They have approximately 480 total participants registered during the course of programming. Every year the program grows and adjusts to the needs of the participants.

The Port Chester Soccer Club has met expectation during the course of its contract for 2011-2012:

- Provided programming for all levels of play
- Established evaluation of players for proper placement
- Constantly updates coaches training and new certifications
- Works to respond and resolve any issues
- Works to make adjustments for future betterment of overall programming
- Provides a safe play environment

The Port Chester Soccer Club works with the Recreation Department, Recreation Commission, and Parks Commission throughout the year providing requested information and attending meetings when necessary. Updates on the soccer program are discussed at every Recreation Commission Meeting.

Cesar Aliaga, President –Port Chester Soccer Club, is in daily contact with the Recreation Department regarding day to day operations.

Port Chester Soccer is an ever growing program. The Port Chester Soccer Club has been able to provide safe, instructional, and competitive play while working with the Village in efforts to make every year more successfully than the previous one. I recommend renewing the Soccer Clubs Annual Contract for 2012-2013.

Should you require anything further please feel free to contact me.

Cc: T. Cerreto
Village Attorney



Durante Rentals, LLC
717 Hutchinson River Pkwy.
Bronx, NY 10465
Phone (718) 239-6969
Fax (718)239-6968

To Port Chester Soccer Club:

The lighting you have expressed an interest in renting from Durante Rentals is routinely used at sporting venues. In fact the following sports clubs have rented the equipment in the last few years:

- Fort Hamilton High School (Fort Hamilton, Brooklyn)
- Manhattan Kickers Soccer (New York City)
- Manhattan Soccer Club (New York City)
- NY Social Sports Club (New York City)
- Ridgefield Football (Ridgefield, CT)
- Super Soccer Stars (New York City)
- Village Lions Rugby (Rockland, NJ)

The use of four light towers is more than adequate to illuminate a regulation sized soccer field after dark for both practices and games.

Any questions please call me.

Tommy Durante
Durante Rentals, LLC
(718) 239-6969

AGREEMENT

This Agreement made the _____ day of August 2012 by and between the VILLAGE OF PORT CHESTER (hereinafter referred to as the "VILLAGE"), a New York municipal corporation located at 222 Grace Church Street, Port Chester, N.Y. 10573, and the PORT CHESTER SOCCER CLUB, INC. (hereinafter referred to as the "CLUB"), a New York not-for-profit corporation, located at 22 Soundview Street, Port Chester, N.Y. 10573.

WITNESSETH

WHEREAS, acknowledging the scarcity of Village resources and the need to secure alternative means of delivery of recreational services, the Village of Port Chester has engaged in public-private partnerships; and

WHEREAS, the Village's relationship with the Port Chester Soccer Club, Inc, is a notable example of such partnerships in the furthering of organized soccer play and is a model for other communities; and

WHEREAS, the parties desire to continue and formalize their partnership.

NOW, THEREFORE, in consideration of the covenants hereinafter set forth, the parties mutually agree as follows:

1. Term: That this agreement shall be for a period of one year, commencing on July 18, 2012 and ending on July 18, 2013.
2. Scope of Services: The Club will solely and exclusively undertake to operate all aspects of the Village Recreation Department's Soccer Program, including youth and adult soccer (hereinafter the "Program").
3. Compensation: In consideration of the services provided, the Village shall make an annual payment to the Club in the amount of \$31,000, said amount being that appropriated in the 2012-2013 Village Budget, and to be paid to the Club no later than July 31, 2012. The payment provided by the Village is for the Program and may only be used by the Club for that purpose.
4. Insurance: The Club shall, at its own expense, procure and maintain at all times general liability insurance with a minimum amount of \$1 million dollars for each occurrence and excess coverage in an additional \$1 million dollars. The Village of Port Chester shall be named as an additional insured. The County of Westchester shall be named as an additional insured with regard to operations at Columbus Park. The Club shall also provide a participant accident medical policy in the minimum amount of \$300,000. The League shall provide evidence of such policies to the Village for review and approval by the Village Attorney.

5. Defense/Indemnification: The Club agrees, to the fullest extent permitted by law, to protect, defend, indemnify and hold the Village of Port Chester, and the County of Westchester with regard to operations at Columbus Park, and any agents, officers, employees and consultants, or any of them, free and harmless from and against any and all losses, penalties, damages, settlements, costs, charges, fees or other expenses or liabilities of any kind and character arising out of or relating to any and all claims, liens, demands, obligations, actions, proceedings, or cause of action of every kind and character in connection with or arising directly or indirectly out of this Agreement and/or the performance hereof. Without limiting the generality of the foregoing, any and all claims relating to personal injury death, damage to property, defects in materials, actual or alleged infringement of any patent, trademark, copyright (or application for any thereof) or of any other tangible or intangible personal or property right, or any actual or alleged violation of any applicable statute, ordinance, local law, administrative order, rule or regulation, decree of any court, shall be included in the indemnity hereunder. The Club further agrees to investigate, handle and provide a defense for and defend any such claims, etc. at its sole expense and agrees to bear all costs and expenses related thereto, even if such claims are groundless, false or fraudulent. In any case in which indemnification would violate Section 5-322 of the New York General Obligations Law, or any other applicable legal prohibition, the foregoing provisions concerning indemnification shall not be construed to indemnify the Village for damage arising out of bodily injury to persons or damage to property caused by or resulting from the sole negligence of the Village or its officers or employees.

6. Independent Contractor: It is understood and agreed that the Club is an independent contractor and that the Village assumes no liability for the means and methods for the Club's operation of the Program. Any persons employed or contracted with by the Club shall not be deemed to be employed or contracted with by the Village in any capacity.

7. Financial Statement: The Club agrees to file a copy of annual financial statement showing revenues and expenditures together with a summary of its operations to the Village upon the execution of this agreement.

8. Use of Facility: The Village shall grant a non-exclusive, revocable license to the Club for the use of the soccer facility at Columbus Park during regular business hours of the Village. Additional such use shall be permitted on the weekdays until 8:30 p.m. and on weekends from 9:00 a.m. to 8:30 p.m. during the fall season (September 1 through November 30) and spring season (March 15 through May 30). The Club shall provide a schedule to the Recreation Department two weeks prior to each season to confirm availability. The Club shall pay a user fee of \$60 for a two-hour game. The Club shall engage a company at its own expense to provide temporary, portable lighting at the soccer facility after dusk. Such light shall be certified by this company as suitable for safe soccer play. The Club shall be responsible for operating and maintaining the lighting during use. The Village reserves the right to suspend or revoke the grant hereunder as it may determine.

9. Meetings: The Club shall provide notice and an agenda of all meetings to the Village. If the Village wishes to attend a meeting to discuss a matter of concern, it shall advise the Club of its intention to attend said meeting.

10. Operational Issues: The Club shall be responsible for resolving issues with regard to the operation of the Program, such as scheduling, determining rosters and determination of play. The Village shall procure and pay for referees and coaches who shall be subject to a background check. The Club shall establish a formal grievance procedure and in the administration of same shall act in good faith and in a non-discriminatory manner. The Village Recreation Department shall be notified within thirty (30) days of such complaint and disposition.

11. Non-Discrimination: The Club shall abide by all applicable state and federal discrimination and human rights law as well as the Village's Anti-Discrimination and Harassment Policy. Any complaint with respect thereto shall be immediately reported to the Village.

12. Complaints: Any written complaints by a resident on the impact of League operations shall be addressed by the Club and responded to by the Club with a plan to resolve the issue. A copy of the complaint and the response to resolve same shall be forwarded to the Village Recreation Department within thirty (30) days of the complaint.

13. Performance Review: This Agreement shall be subject to an annual review no less than ninety (90) days prior to the expiration of the term.

14. Notices: All correspondence under this agreement shall be sent as follows:

For the Village:

Christopher J. Russo
Village Manager
Village of Port Chester
222 Grace Church Street
Port Chester, N.Y. 10573

For the Club:

Caesar Aliaga
Port Chester Soccer Club, Inc.
Port Chester, N.Y. 10573

15. This agreement is entire and shall not be altered or amended except by a writing signed by the parties hereto.

16. If any clause, paragraph, section or part of this Agreement shall be determined by a court of competent jurisdiction to be invalid, the judgment shall not affect the validity of this Agreement as a whole or any part thereof other than the part determined to be invalid.

17. The Port Chester Park and Recreation Commission have approved the Club's continued operation of the Village's soccer program.

IN WITNESS WHEREOF the parties hereto have set their hands and seals the day and year first above written.

Approved as to Form:

Village Attorney

VILLAGE OF PORT CHESTER

By: _____
Christopher J. Russo, Village Manager

PORT CHESTER SOCCER CLUB, INC.

By: _____
Its' President

B/T Mtg. Date July 16, 2012	Action: <input type="checkbox"/> Adopted
Village Clerk	<input type="checkbox"/> Defeated
Resolution # <u> 1 </u>	<input type="checkbox"/> Tabled
	<input type="checkbox"/> No Action
Motion 1 <u> </u> 2 <u> </u>	<input type="checkbox"/> Amended

RESOLUTION

On motion of TRUSTEE _____, seconded by TRUSTEE, the following resolution was adopted by the Board of Trustees of the Village of Port Chester, New York:

WHEREAS, by letter dated June 27, 2012, Capital Enterprises, Inc. d/b/a the Capital Theater, which was subsequently forwarded to the Village Clerk, the Village has been advised that an application will be made to the New York State Liquor Authority for approval of substantial alteration to premises located at 149 Westchester Avenue; and

WHEREAS, unless waived applicants for liquor licenses are required to provide 30-day advance notice to a municipality so that it may provide comment to the Liquor Authority; and

WHEREAS, the Police Department and Building Department have since advised that it has no objection to same. Now, therefore, be it

RESOLVED, that the Board of Trustees has no objection to the application of Capital Enterprises, Inc. d/b/a the Capital Theater, 149 Westchester Avenue, for approval of a substantial alteration to the subject premises; and be it further

RESOLVED, that the Village Clerk be directed and authorized to provide a certified copy of this resolution to the State Liquor Authority.

Vote:	Aye	Nay	Abstain	Absent
Brakewood				
Terenzi				
Didden				
Branca				
Kenner				
Marino				
Pilla				

B/T Mtg. Date July 16, 2012	Action: <input type="checkbox"/> Adopted
Village Clerk	<input type="checkbox"/> Defeated
Resolution # <u> 2 </u>	<input type="checkbox"/> Tabled
	<input type="checkbox"/> No Action
Motion 1 <u> 2 </u>	<input type="checkbox"/> Amended

RESOLUTION

On motion of TRUSTEE _____, seconded by TRUSTEE, the following resolution was adopted by the Board of Trustees of the Village of Port Chester, New York:

WHEREAS, by letter dated June 27, 2012, Capital Enterprises, Inc. d/b/a the Capital Theater, which was forwarded to the Village Clerk, request has been made to continue and expand the use of the existing sidewalk vault on the Broad Street frontage of the premises located at 149 Westchester Avenue; and

WHEREAS, such request is made as part of ongoing renovations being made to the theater; and

WHEREAS, Board action would formalize an apparent long-standing special use of the sidewalk. Now, therefore, be it

RESOLVED, that the Board of Trustees hereby grants permission in the form of a revocable license to Capital Enterprises, Inc. d/b/a the Capital Theater to continue and expand the use of the existing sidewalk vault on the Broad Street frontage of the premises located at 149 Westchester Avenue, subject to such terms and conditions as may be imposed by the Village Manager or his designee.

Vote:	Aye	Nay	Abstain	Absent
Brakewood				
Terenzi				
Didden				
Branca				
Kenner				
Marino				
Pilla				

THE LAW OFFICE OF

Anthony R. Tirone, Esq., P.C.

10 BANK STREET, SUITE 650
WHITE PLAINS, NEW YORK 10606
TEL: 914-686-7007 • FAX: 914-686-7019
ARTirone@msn.com

VIA CERTIFIED MAIL ARTICLE NUMBER 7011 2000 0002 3777 0256
RETURN RECEIPT REQUESTED

June 27, 2012

Mr. Anthony M. Cerreto, Esq.
Village of Port Chester
222 Grace Church Street
Port Chester, NY 10573



**Re: The Capitol Theatre
NYS/SLA 30 day advance notice for On-Premises License
Application for Permission to Make Alterations**

Dear Mr. Cerreto:

We represent Capital Enterprises, Inc. d/b/a The Capital Theatre. As part of our licensing process we are applying to the NYS/SLA for alterations to the current On-Premises alcohol license. As part of that process we are submitting the application to the SLA for a proposed "Substantial Alteration".

Enclosed herein please find our 30 day advance notice to the Village of Port Chester for our Application for Permission to Make Alterations for the establishment identified in this notice. We would greatly appreciate if you or your licensing authority has any objections to address them to us immediately. In the alternative, since you have already issued the building permit under **Permit Number B-2012-194** a letter of approval/consent or non-objection would be greatly appreciated forthwith.

Thank you for your attention to this matter. Please advise if you require any additional information, have questions or concerns.

Respectfully submitted,

A large, stylized handwritten signature in black ink, which appears to be "Anthony R. Tirone".

Anthony R. Tirone

ART:yl

Enclosure

CC: Mr. Peter Shapiro

Mr. Joseph M. Krzeminski, Chief of Police of The Village of Port Chester

Mrs. Joan Mancuso, Clerk of The Village of Port Chester

The Hon. Dennis Pilla, Mayor of The Village of Port Chester



STATE OF NEW YORK
EXECUTIVE DEPARTMENT
DIVISION OF ALCOHOLIC BEVERAGE CONTROL
STATE LIQUOR AUTHORITY

Standardized **ALTERATION APPLICATION NOTICE FORM** for Providing a
30-Day Advance Notice to a Local Municipality or Community Board
In connection with the submission to the State Liquor Authority of the
Application for Permission to Make Alterations
for the Establishment Identified in this Notice

1.	Date the Original copy of this Notice was Mailed to the Local Municipality or Community Board:						0	6	2	7	2	0	1	2				
THIS 30-DAY ADVANCE NOTICE IS BEING MAILED TO THE CLERK OF THE FOLLOWING LOCAL MUNICIPALITY OR COMMUNITY BOARD:																		
2.	Name of the Local Municipality or Community Board:						VILLAGE OF PORT CHESTER											
3.	Street Address of Local Municipality or Community Board:						222 GRACE CHURCH STREET											
4.	City, Town or Village:						PORT CHESTER				NY		Zip Code: 10573					
5.	Telephone Number of Clerk of Local Municipality or Community Board:						9	1	4	-	9	3	9	-	5	2	0	0
APPLICANT INFORMATION																		
6.	Applicant's Full Name as it Appears on the License Certificate:									License Serial No.								
CAPITAL ENTERPRISES, INC.									1263694									
7.	Street Address of Premises				City, Town or Village-Zip Code				County		Telephone No.							
149 WESTCHESTER AVENUE				PORT CHESTER 10573				WESTCHESTER		(914) 937-4126								
8.	Type(s) of Alcohol Currently Sold under the License: ("X" one)						<input type="checkbox"/> Beer Only		<input type="checkbox"/> Wine and Beer Only		<input checked="" type="checkbox"/> Liquor, Wine and Beer							
PROPOSED CHANGES/ALTERATIONS																		
9.	<p style="text-align: center;"><u>Check One</u></p> <input checked="" type="checkbox"/> Substantial Alteration: Any enlargement or contraction of a licensed premises. Any physical changes to the exterior, that involves the creation or relocation of any window or door, and any interior changes of physical structure. Any change in size or location of bar, or dining and kitchen facilities. or <input type="checkbox"/> Minor Alteration: One costing and valued at less than ten thousand dollars, which does not affect the material character or physical structure that existed at the time of licensing.																	
10.	Where will the Alteration be confined to?						<input checked="" type="checkbox"/> Interior		<input type="checkbox"/> Exterior		<input type="checkbox"/> Interior and Exterior		If interior, will the Occupancy change? Yes or No NO					
11.	If Exterior, do you plan on utilizing outdoor areas? Yes or No N/A				If Yes, which outdoor area? Check One <input type="checkbox"/> Rooftop <input type="checkbox"/> Patio or Deck <input type="checkbox"/> Freestanding Covered Structure <input type="checkbox"/> Garden/Grounds <input type="checkbox"/> Other													
12.	Is a Building Permit required for this type of Alteration? Yes or No YES						If so, has permit been applied for? Yes or No YES - GRANTED											
13.	Will any entrance or exit of premises as altered be within 200' of the entrance to a school, church or synagogue or other place of worship? Yes or No NO						Will there be a change of address upon completion of Alterations? Yes or No NO											
14.	Are there any known limitations by the County or Municipality for this type of Alteration? Yes or No NO						Is so, what are they?											
ATTORNEY OR REPRESENTATIVE REPRESENTING THE APPLICANT IN CONNECTION WITH THE APPLICANT'S ALTERATION APPLICATION FOR THE ESTABLISHMENT IDENTIFIED IN THIS NOTICE																		
15.	Attorney's Full Name is: ANTHONY R. TIRONE, ESQ.																	
16.	Attorney's Street Address:				City, Town or Village:				Business Telephone Number:									
10 BANK STREET, SUITE 650				WHITE PLAINS, NY				(914) 686-7007										

I am the Person who holds the license or I am a Principal of the Legal Entity that will hold the License.
Representations in this form are in full conformity with representations made in documents that have been submitted (or documents that will be submitted) to the State Liquor Authority and relied upon by the Authority.
I understand that representations made in this form will also be relied upon by the Authority and that false representations in any document submitted to the Authority may result in revocation of any license that may be issued.
By my signature, I affirm under Penalty of Perjury that the representations made in this form are true.

Printed Name	Title	Signature
PETER S. SHAPIRO	OWNER	

THE LAW OFFICE OF

Anthony P. Tirone, Esq., P.C.

10 BANK STREET, SUITE 650
WHITE PLAINS, NEW YORK 10606
TEL: 914-686-7007 • FAX: 914-686-7019
ARTirone@msn.com

BY HAND

July 13, 2012

Anthony M. Cerreto, Esq.
Mr. Chris Gomez, AICP
Village of Port Chester
222 Grace Church Street
Port Chester, NY 10573

**Re: The Capitol Theatre
Broad Street Vault Access Sidewalk Easement**

Dear Mr. Cerreto and Mr. Gomez:

We represent Capitol Enterprises, Inc. d/b/a The Capitol Theatre. As part of the current renovations and building code compliance we are proposing to continue and expand the use of the Broad street sidewalk easement vault opening as detailed below.

The building is located at the corner of Westchester Avenue and Broad Street. The basement space of the Capitol runs under the sidewalk to the edge of the roadway on the Broad Street side, thereby creating "vault" space under the sidewalk.

The original plans (*attached hereto*) detail that the subject "vault" space has been in existence since the building was erected in or about 1928. In addition, the vault space, which was used for coal, ash, oil and deliveries, has always had exterior access through the sidewalk on Broad Street. (*Please see the maps and pictures attached hereto*). That exterior access use has been continuous since 1928; open, obvious and done under a color of right although no formal easement or permissive license is of record. We would like to formalize the "*permissive easement w/a revocable license*" to ensure its continued use and for the protection of the Village.

On behalf of Capitol Enterprises, Inc. d/b/a The Capitol Theatre, we are hereby requesting permission from the Village of Port Chester to allow the continued and expanded use of the sidewalk vault opening. We are requesting a formal resolution by your Board for the issuance of an agreement between The VPC and The Capitol Theatre for a "permissive easement w/a revocable license running to the benefit of the Village of Port Chester" over the sidewalk above the Capitol's vault space on Broad Street.

In concurrence with the permissive use easement Capitol Enterprises, Inc. d/b/a The Capitol Theatre hereby agrees to indemnify and defend The Village of Port Chester, with respect to the Capitol's use of the vault space sidewalk opening.

In light of the fact that the current the sidewalk opening is very old, we are concurrently requesting permission to expand the opening from the current 3x4 cutout to a 5x5 cutout.

The new opening will be fitted with a state of the art "*material lift*" making delivers to the basement cold storage area efficient and safe. The plans for the installation of the material lift use have been submitted to the Building Dept and approved *subject to* a permissive use easement being issued by your Board. I have attached for you review the building specifications, interior photos, current exterior and proposed exterior view photos.

We would greatly appreciate it if you or your licensing authority has any objections to address them to us immediately. In the alternative, since you have already issued the building permit under **Permit Number B-2012-194** a formal Board resolution of approval would be greatly appreciated.

Thank you for your attention to this matter. Please advise if you require any additional information.

Respectfully submitted,



Anthony R. Tirone

ART:nr
Enclosures

CC: Mr. Tom Bailey; GM The Capitol Theatre
Board of Trustees of The Village of Port Chester
Clerk of The Village of Port Chester
The Hon. Dennis Pilla, Mayor of The Village of Port Chester

← WESTCHESTER AVENUE →

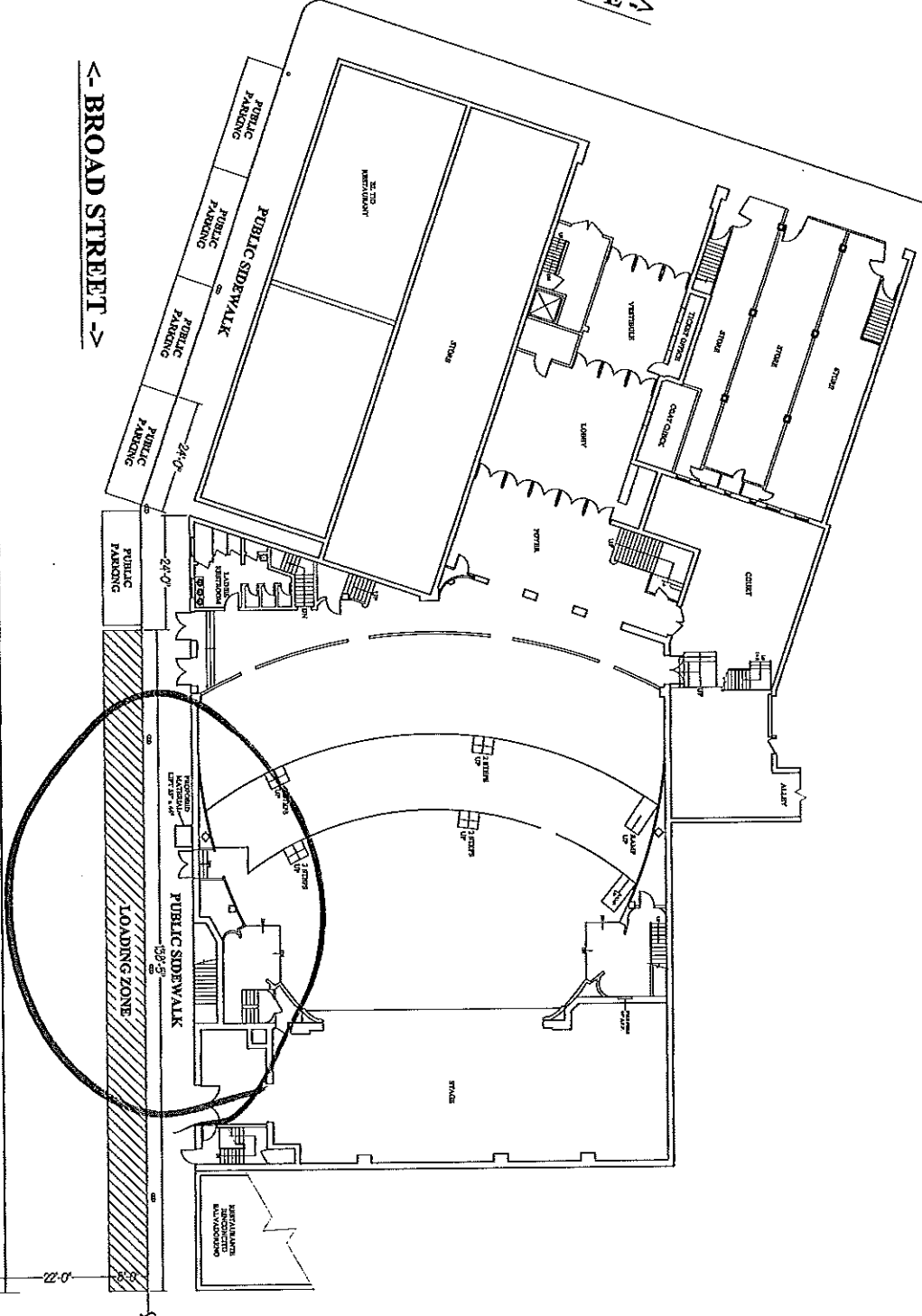
← BROAD STREET →



FIRST FLOOR/SIDEWALK PLAN
SCALE: 3/32" = 1'-0"

PUBLIC PARKING

PUBLIC SIDEWALK

LOADING ZONE

OWNER INFO	SCOTT RAYED NEW YORK, NY
CLIENTELE INFO	NAME: SCOTT RAYED ADDRESS: NEW YORK, NY
DATE	02-05-2012
PROJECT NO.	2012002
DRAWN BY	GLP
CHECKED BY	FG
PROJECT NO.	A-00000
DATE	10/05/11
PROJECT NO.	10094

NO.	REVISIONS:	DATE	BY

feingold & gregory · architects
118 West 83rd Street · New York, N.Y. · 10024
Tel.: (212) 255-0255 · Fax: (212) 737-8702



NO.	REVISIONS:	DATE	BY

Revisions: 04-20-2012

PROJECT ISSUES NO RESPONSIBILITY FOR ANY WORK WHICH MAY BE REQUIRED TO BE CORRECTED OR FOR ANY OTHER WORK WHICH MAY BE REQUIRED TO BE CORRECTED FOR ANY REASON FROM THE PROJECT BEFORE COMMENCING CONSTRUCTION.

FOR FINISHES, SEE SPECIFICATIONS OF THE LOCAL BUILDING DEPARTMENT. THIS DRAWING IS THE PROPERTY OF THE BILCO COMPANY. IT IS TO BE USED ONLY FOR THE PROJECT AND AT THE LOCATION SPECIFIED HEREON. ANY REUSE OR REPRODUCTION OF THIS DRAWING WITHOUT THE WRITTEN CONSENT OF THE BILCO COMPANY IS STRICTLY PROHIBITED. ALL RIGHTS RESERVED. ALL DIMENSIONS ARE IN INCHES UNLESS OTHERWISE SPECIFIED.

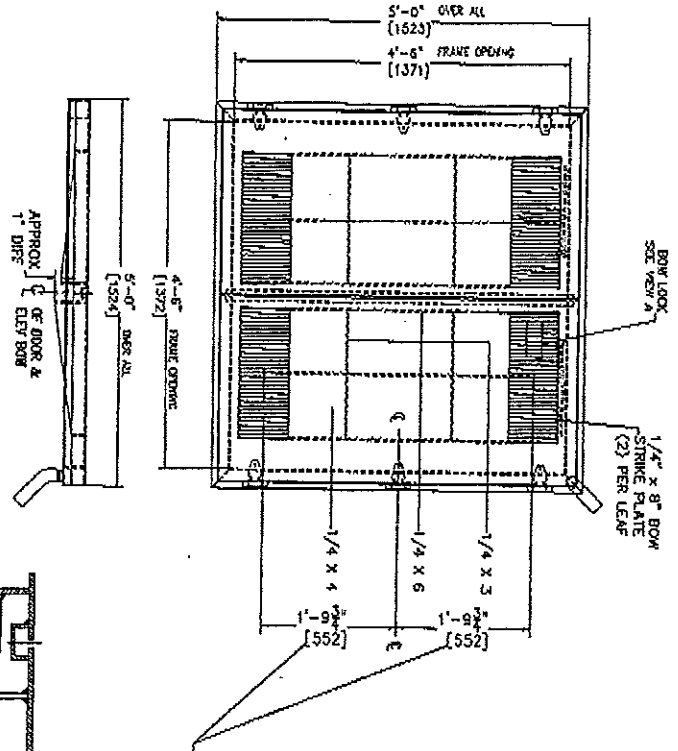

NOTE:
PLEASE VERIFY
PROPORTION THAT % OF
BOW STRIKE PLATE IS
LOCATED ON % OF
ELEVATOR BOW

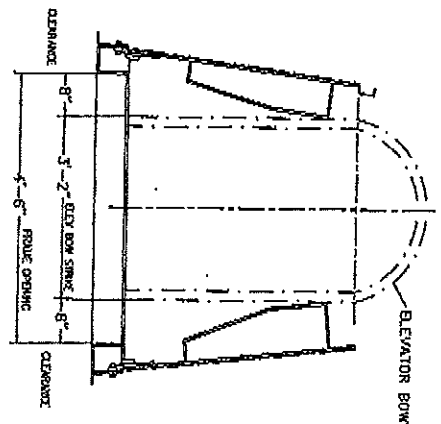

NOTE:
A MIN CLEARANCE OF 7" MUST BE MAINTAINED BETWEEN FRAME OF DOOR AND EDGE OF ELEVATOR BOW. THIS ALLOWS THE RIGHT OF THE LEAVES TO REST AGAINST THE ELEVATOR AT ALL TIMES. THEREFORE, THE LEAVES WILL CLOSE AUTOMATICALLY WHEN ELEVATOR BOW IS LOWERED

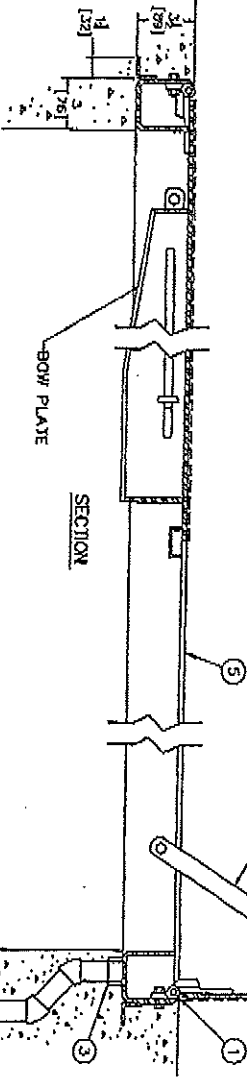

VIEW A
BOW LOCK

BOW PLATE

INSTALLER NOTES:

- A. Use caution. Door is spring loaded. Do not remove safety springing bolt until unit is to be installed and is locked horizontal opening position.
- B. Place on opening so that the handle is in desired location. Be sure unit is set on slight pitch toward dash corner.
- C. Before attaching in place open and close door. Check to see that the door is closed position rests on the frame all around. If not, adjust under the frame of the proper corner.
- D. Do not reduce 1 1/2" drain pipe to dry well or disposal system.

SPECIFICATIONS:

- 1 Bilco Heavy duty forged brass hinges with stainless steel pins
- 2 Guide arm
- 3 1-1/2" drain coupling
- 4 1/4" steel diamond pattern plate cover
- 5 Bilco 1/4" slot channel with welded 1 1/4" x 3 1/4" endtor flange

1 UNIT(S) REQUIRED AS SHOWN (Sheet Adjustment)
COVER REFR. FOR 300 Lbs. PER Sq. Ft.

SHOP FINISH:
COVER: RED BRONZE FINISH
FRAME: RED BRONZE FINISH
HARDWARE: ZINC PLATED & CHROMIUM SEALER

Manufacturer: ESSEX RISE CONVERTERS CORP
417 FRENCH CRESSSENT
417 FRENCH CRESSSENT
6231-408

Job: NORTH MICHIGAN AVE CHICAGO

Builder:

Architect:

Sales Rep: CONYAKA, JERIN, SALES CORP
3120 EXPRESSWAY DR. #207H
ISLANDIA, NY

Bilco
THE BILCO COMPANY
New Haven, Connecticut 06508

TYPE "JE" STEEL DOUBLE LEAF ELEVATOR
DOOR - SIZE 4'-5" x 4'-5"

Order No.	Date	Drawing No.	Rev.
SA1182	6-7-12	JE-402	A
Scale:	DO NOT SCALE		

Street level - 1926 blueprints

F-4 Avery_3621.18.pdf (1 page) - loc:105

carb line

opening

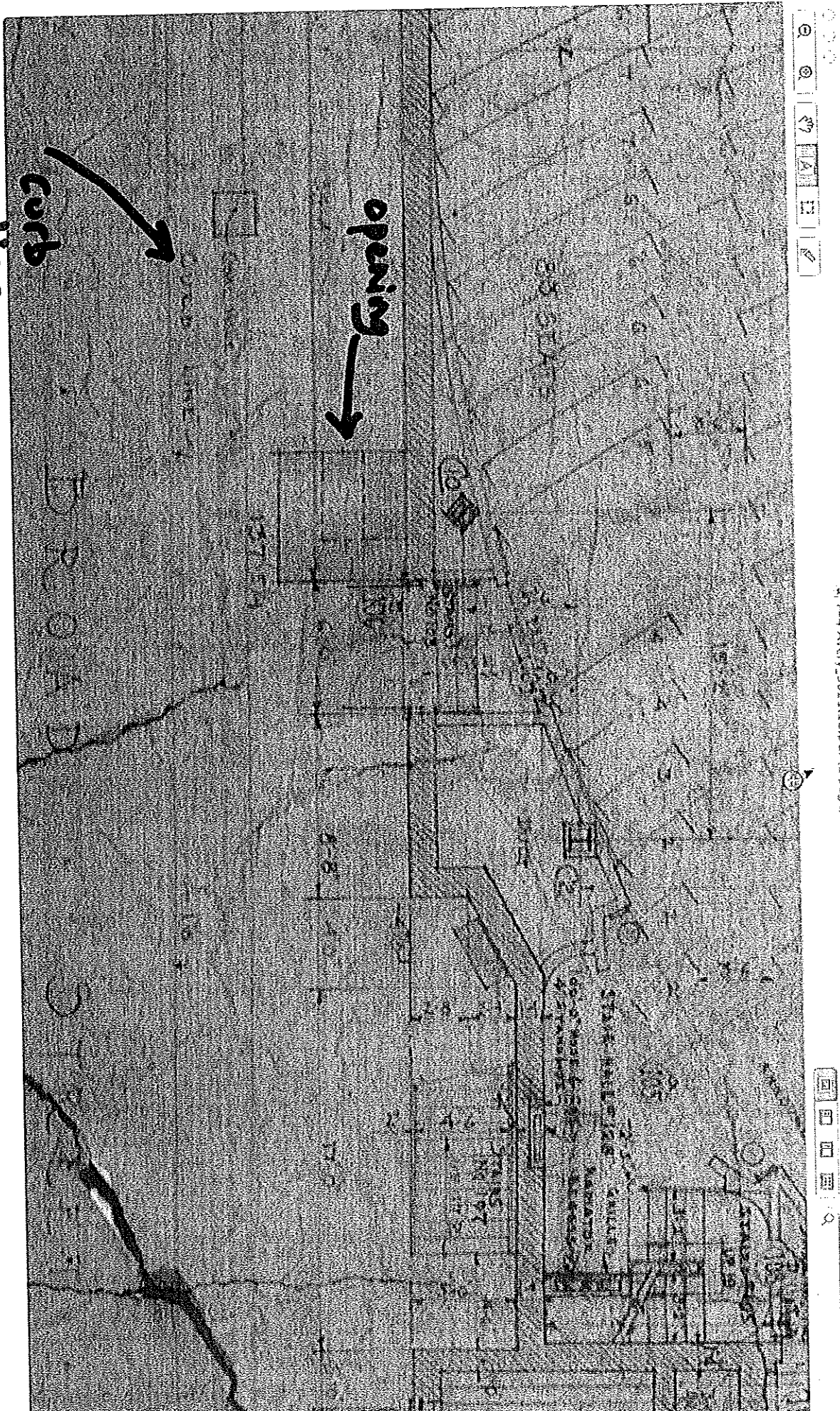

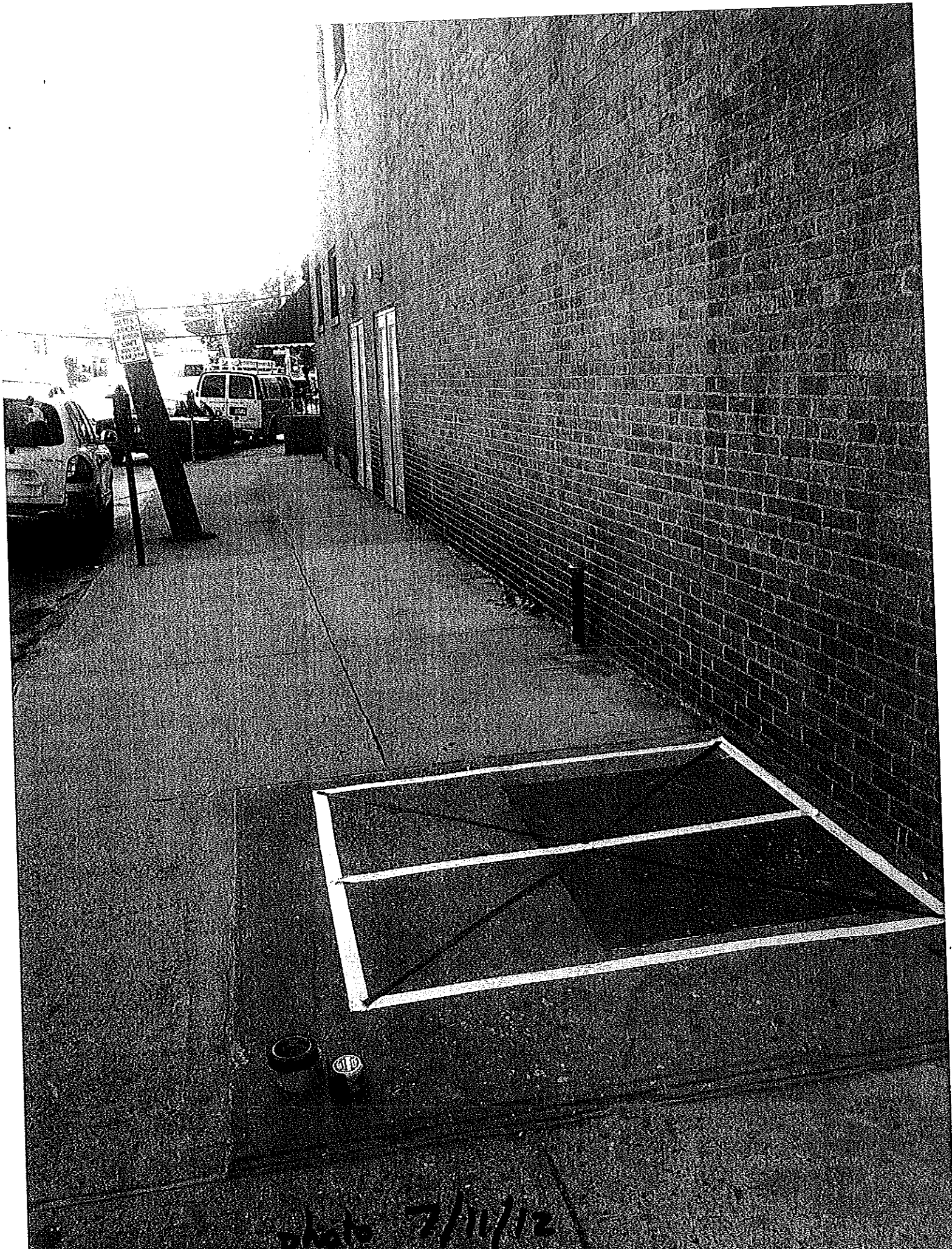

photo 3/11/12





photo 7/11/12

Capitol Theatre
sidewalk vault

← Broadway
Street

↑
underside of
existing sidewalk
opening (as shown in
1926 blueprints)

ladder →

photo 7/11/12

ESSEX RISE CORPORATION

4 FAIRFIELD CRESCENT
 WEST CALDWELL, NEW JERSEY 07006
 (973)575-7483 FAX:(973)575-0576
 E-MAIL: SBOHANON@ESSEXRISE.COM

LETTER OF TRANSMITTAL

DATE:	4/27/2012	JOB No.	ER6232
ATTN:	MR. SCOTT RAVED		
RE:	SIDEWALK LIFT		

TO: DATWYLER PHARMA PACKAGING
9012 PENNSAUKEN HIGHWAY
PENNSAUKEN, NJ 08110

WE ARE SENDING YOU ATTACHED THE FOLLOWING ITEMS:

XXX PRINTS SHOP DRAWINGS SPECIFICATIONS
 CORRESPONDENCE

COPIES	DATE	DWG. NO.	DESCRIPTION
	04-25-12	6232-GA	GENERAL ARRANGEMENT
	04-25-12	6232-W1	ELECTRIACAL SCHEMATIC
	04-25-12	6232-W2	ELECTRIACAL SCHEMATIC
			SAMPLE SIDEWALK DOOR

THESE ARE TRANSMITTED AS CHECKED BELOW:

XXX FOR APPROVAL FOR YOUR USE AS REQUESTED FOR REVIEW AND COMMENT
 XXX RETURN ONE COPY OF EACH WITH SIGNED APPROVAL CERTIFIED AS BUILT

REMARKS: _____

SIGNED: Shawn Bohanon

LIFT CYLINDER

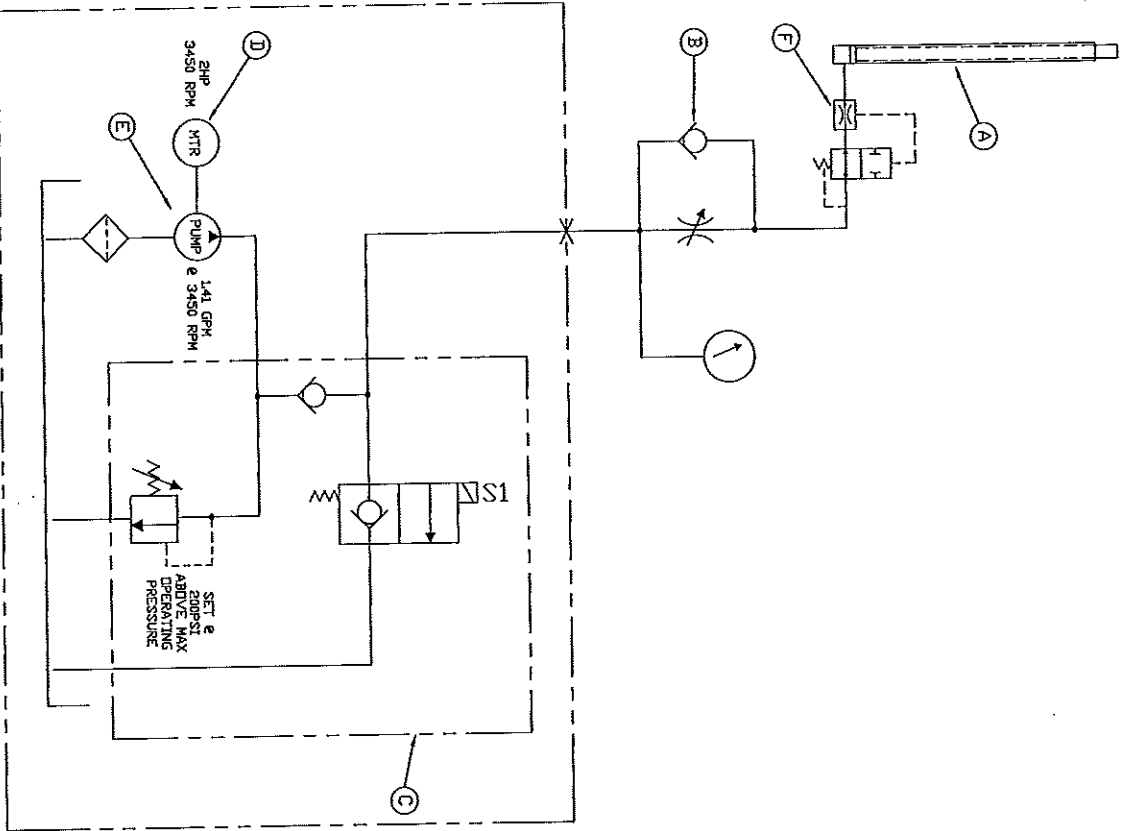

BILL OF MATERIAL			
ITEM	QTY	MFG	DESCRIPTION - CATALOG NO.
A	1	ESSEX	CYLINDER - 0200-87-250
B	1	DELTRRL	FLOW CONTROL VALVE - F255
C	1	STONE	L-H-L VALVE KIT - KC01G-M
D	1	STONE	MOTOR - KMC24
E	1	STONE	PUMP - KP31
F	1	VONBERG	VELOCITY FUSE - 28001-503-5.0

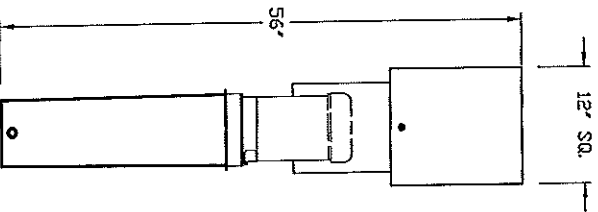

HPU AND CONTROL CABINET
TO BE WALL MOUNTED VERTICALLY

REV	DATE	BY	CHECKED	DESCRIPTION	CUSTOMER P.O. NO.	DATE
ESSEX • RISE CORPORATION				ORDER NO.	6232-H1	
HYDRAULIC SCHEMATIC				DATE	04-25-72	
THE CAPITOL THEATER						

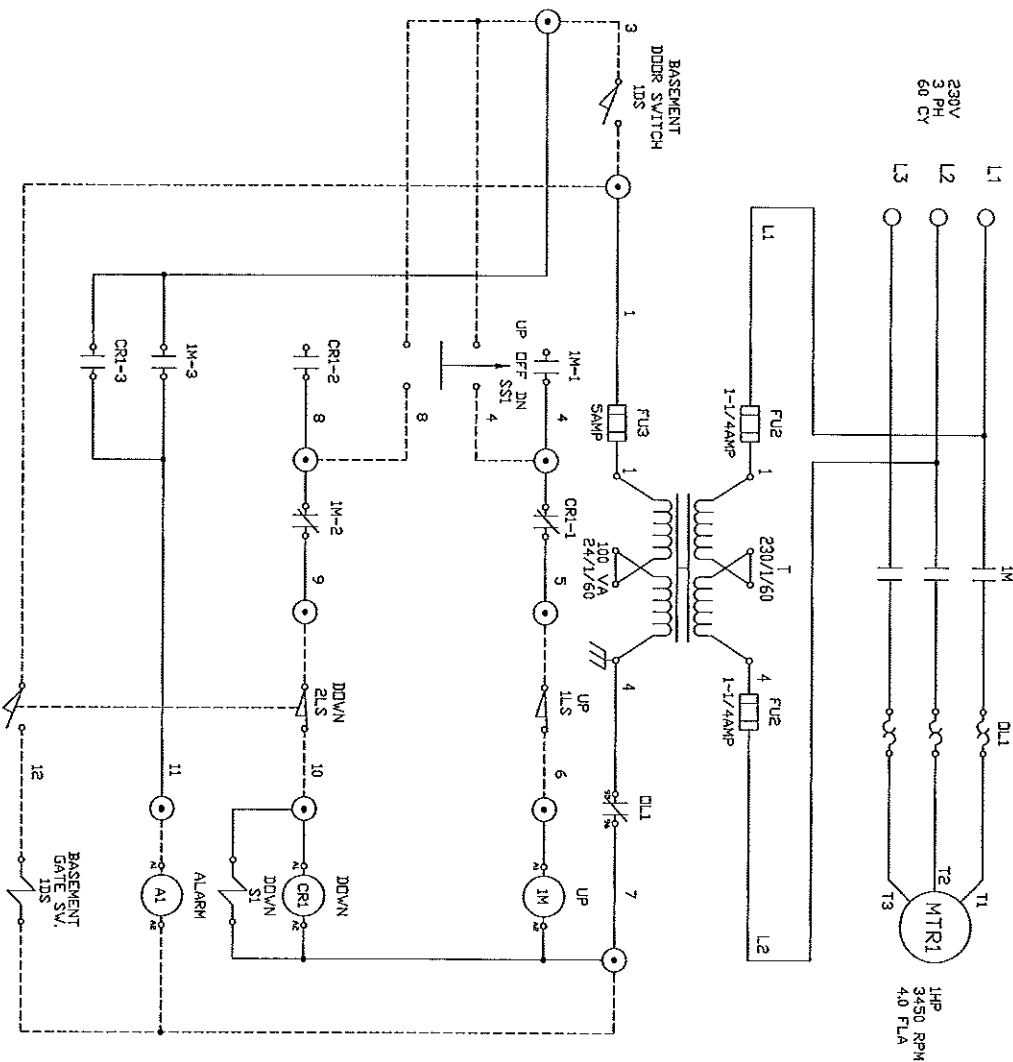

BILL OF MATERIALS

ITEM QTY	MFG	DESCRIPTION - CATALOG NO.
* 1M 1	AUTO	CONTACTOR - SC-E02-24VAC W/SZ-AE2T
* DL1 1	AUTO	OVERLOAD - TK-E02-600
* CRI 1	AUTO	RELAY - 784-4C-24A W/784-4C-SKT-1
1,2,3 2	DMRDN	LIMIT SWITCH - DAA-1101N/COO
SSI 1	AB	SELECTOR SWITCH - 800T-J631A
AI 1	AB	ALARM - 855H-BA24AD
* T 1	AUTO	TRANSFORMER - PH100PG
* FUI 2	BUSS	FUSE - FNO-R-1-1/4
* FUE 1	BUSS	FUSE - FNM-5
IDS 1	STI	DOOR INTERLOCK - 44534-0370

GENERAL NOTES

- 1) ALL WIRING AND CONTROLS TO MEET NEMA 3R REQUIREMENTS
- 2) ALL CONDUIT AND FITTINGS TO BE 1/2" EMT WITH COMPRESSION FITTING AND SEALTITE, SEALTITE NOT TO EXCEED 36" LONG
- 3) CONDUCTORS AS FOLLOWS:
 - 14 AWG THIN BLACK POWER/PRIMARY
 - 16 AWG THIN RED 120VAC CONTROL
 - 16 AWG THIN WHITE NEUTRAL
 - 14 AWG THIN GREEN GROUND
- 4) DENOTES FIELD WIRING BY INSTALLER
- 5) BOM ITEMS MARKED WITH AN ASTERISK ARE PANEL MOUNTED
- 6) CAB LIGHTING CIRCUIT VOLTAGE TO BE SUPPLIED BY PURCHASER AND IS TERMINATED IN THE FRAME MOUNTED J-BOX

REV	DATE	BY	ORDER	DESCRIPTION	CUSTOMER P.O. NO.	###
ESSEX RISE CORPORATION			6232-V1			
MATERIAL LIFT ELECTRICAL SCHEMATIC			THE CAPITOL THEATER			
SCALE	NTS	DATE	04-25-12	BRAND	NSB	

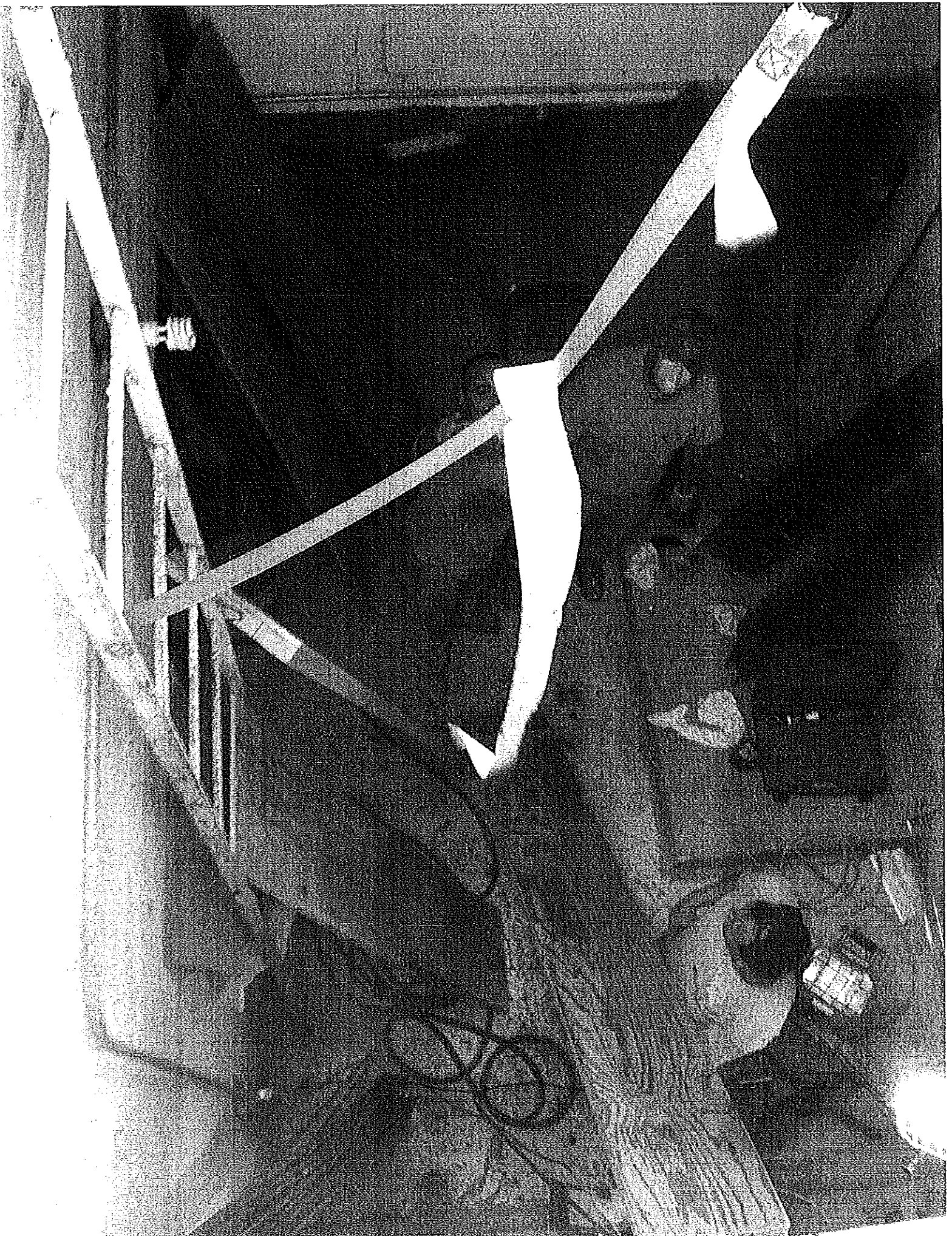

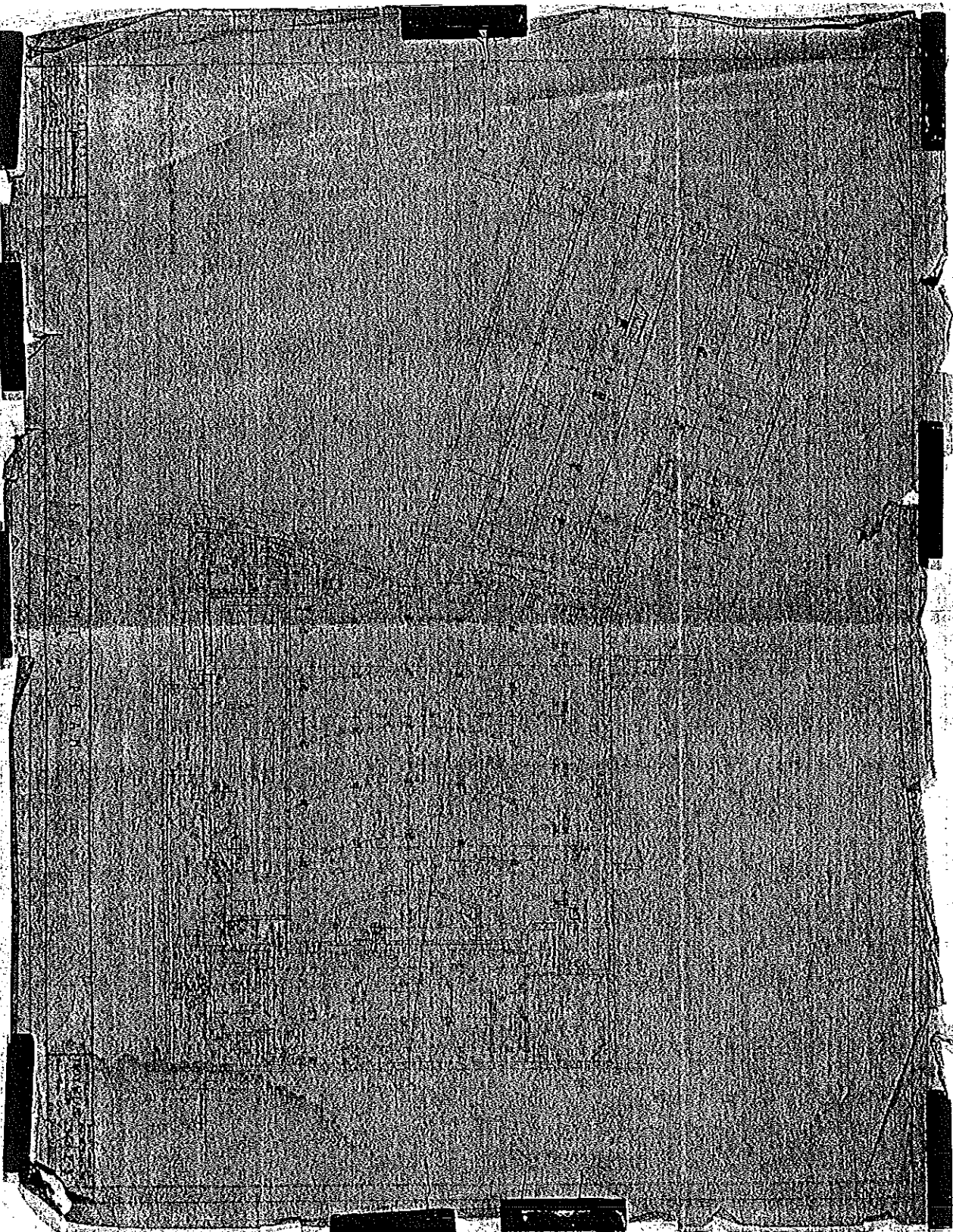

on
file at
Columbia
Univ.
School
of
Architecture

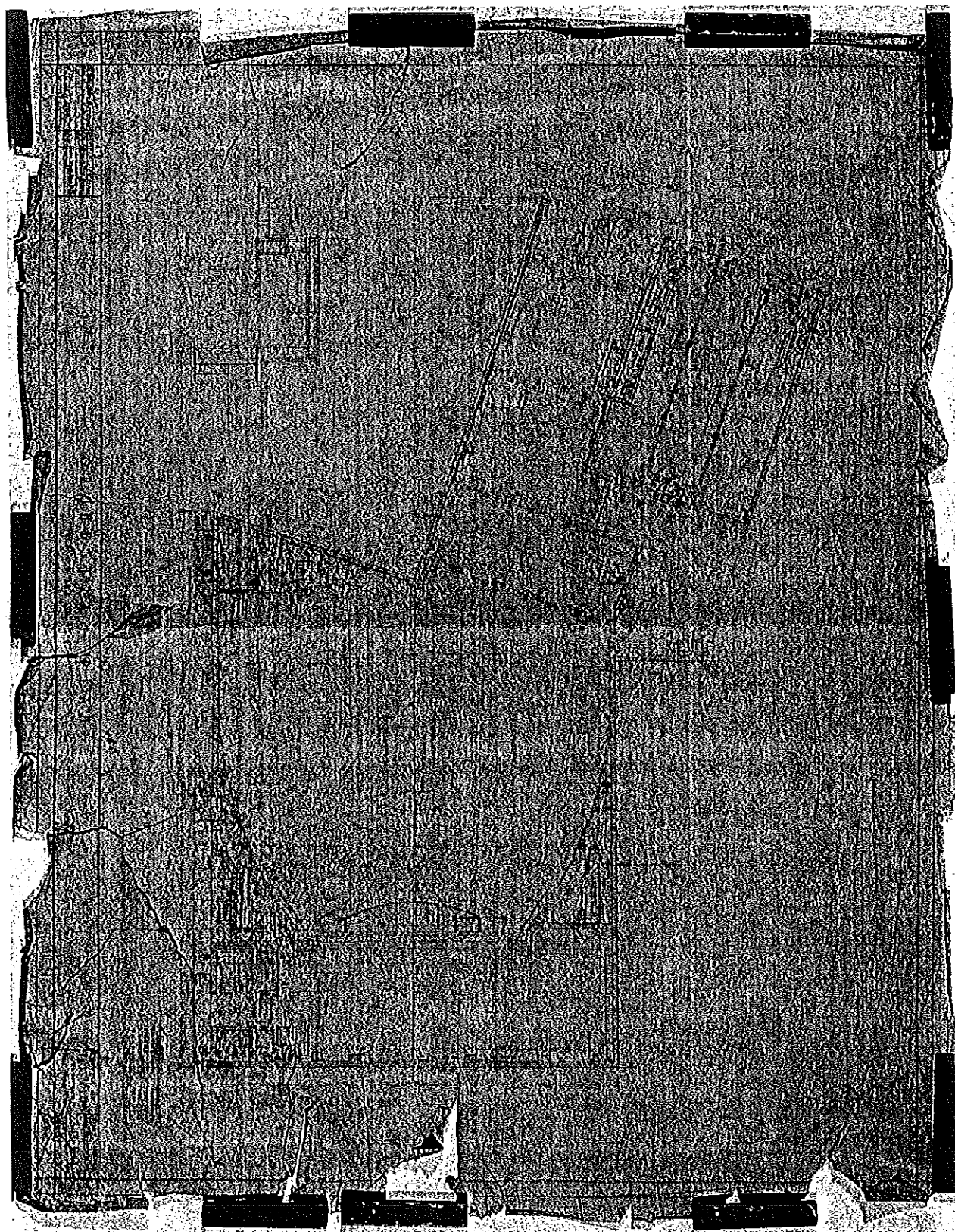

July 3, 2012



Dear Mr. Mayor and Board of Trustees,

The residents of Glendale Place are interested in having a "block party" on Glendale Place on July 21, 2012. We are asking for the road to be blocked from traffic at the end of Glendale and Leicester and the end of Glendale and Cleremont.

We would like to have the street closed from 2:00pm to 8:00pm.

Thank you for your consideration. We look forward to hearing from you!

Sincerely,

Pamela and Joseph McHugh

88 Glendale Place
Port Chester, NY 10573

914-934-8773



Saint Peter's Episcopal Church † Iglesia Episcopal San Pedro

To: The Hon. Mayor and Trustees
Village of Port Chester

From: The Rev. Hilarlo Albert,
Priest In Charge
St. Peter's Episcopal Church



Subj. " **Virgin Assumption**" Procession
(A Patron of the Peruvian community)

The "**St. Mary the Virgin The Assumption**" is venerated by several Peruvian communities. The Peruvian Community is very diverse and each community has their own way of veneration and celebration.

At Saint Peter's Episcopal Church, Port Chester we have several people who are devoted to the "**St. Mary the Virgin The Assumption**" and for several months have met to plan for a celebration at St. Peter's Church.

Today we are asking permission for a procession on Saturday, August 25, 2012 as part of this religious celebration. The procession will leave from 466 Westchester Ave. Port Chester, and will cross Westchester to Erving St. The Group will process on Erving from South Ave. to North and make right at Poningo St. to cross Westchester to enter the Church through Smith Street. We expect a crowd between 50 to 70 people. The procession will start at 4:00pm and will arrive at St. Peter's Church no later than by 5:00pm.

If any more information is needed please contact The Rev. Hilarlo Albert, priest in charge at 914-939-1244 Monday -Friday from 10am to 4:00pm; person running the Procession Ruben Barriga; phone 203-362-8685.

Very Truly,

Rev. Hilarlo Albert-PIC

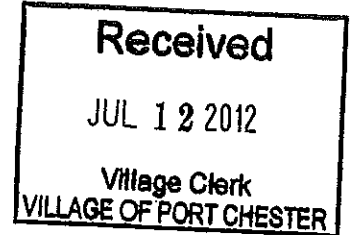

July 9, 2012

Mayor Dennis Pilla and Village Board of Trustees
Village of Port Chester
222 Grace Church Street
Port Chester, NY 10573

Dear Mayor Pilla and Village Board of Trustees:

On behalf of the Centro Cultural Boliviano, we are seeking permission to place a banner across Westchester Avenue and Main Street to advertise the Bolivian Culture Parade to be held on Sunday, August 26, 2012.

If permission is granted, we are also seeking permission for the Village Highway Department to place the banners for us.

Very truly yours,

Centro Cultural Boliviano



COUNCIL OF COMMUNITY SERVICES
PORT CHESTER · TOWN OF RYE · RYE BROOK

July 11, 2012

Board of Directors

Pastor Jim O'Hanlon
President

Sally M. Adler
First Vice-President

Scott Moore
Second Vice-President

Kerry Walsh
Treasurer

Sheila Filipowski
Recording Secretary

Rev. Hilario Albert
Corresponding Secretary

Fr. Richard Alejunas
 Doris Bailey-Reavis
 Rev. J. Bruce Baker
 Kathy Carley-Spanier
 Lindsay Farrell
 Michael Goldstein
 John D. Hlensch
 Blanca P. Lopez
 Isobel Perry
 John Reavis
 Elizabeth Rotfeld
 Susan Wayne
 Caryl Weinstein
 Rev. Natalie Wimberly

Community Advisory Council

Hon. Joseph Carvin, Jr.
 Daniel Colangelo
 Dr. Mitchell Combs
 Frank Fanelli
 Joan Grangenio-Thomas
 William Guerrero
 John Kiyak
 Dr. Edward Kliszus
 Barbara Mallaney
 Hon. Judy Myers
 Carol Nielsen
 Hon. Suzi Oppenheimer
 Hon. Dennis Pilla
 Allan Rentz
 Christopher J. Russo

Council Committees

Port Chester Arts Initiative
 and Port Chester Fest
 Adolescent Health Task Force
 Port Chester Cares
 Community Coalition
 God's Green Market
 Health Network
 Housing Task Force
 Latino Network
 Mary O'Connell Camp Fund
 Senior Network

Executive Director
 Daniel Lipka

Mayor Dennis Pilla and Members of the Village Board of Trustees
 Village of Port Chester
 222 Grace Church Street
 Port Chester, New York 10580

Re: Update on Port Chester Fest

Dear Mayor Pilla and Members of the Board of Trustees:

The Port Chester Council of Community Services is happy to report that after working with the Port Chester Police and local businesses, that we have been given space for the Port Chester Fest that will not cause any additional increase to local traffic or impact local businesses.

Similar to previous years, this plan requires the closure of the segment of Purdy Ave, between Don Bosco and Grace Church St. We plan to utilize the uncovered portion of the Stop&Shop parking lot across the street from Purdy Ave. We have received permission from the owners of the property, G&S Investors. We have also received permission from both the Store Manager and the Regional Manager of Stop&Shop. We will also utilize the parking lot at 1 Gateway Plaza. We have received permission from the only business in that complex that will be open the day of the event. This plan was created in collaboration with the Village Manager, the Police Department, DPW, and the Department of Recreation.

We need the following Village support to make this a reality:

- Provide the appropriate Police support to close of Purdy Avenue, between Grace Church Street and Don Bosco (8:00am – 6:30pm).
- Police and Department of Public Works services
- Support from the Village Recreation Department of the day of the event.
- Public toilets
- Showmobile, with generator
- Permission to fly a banner over North Main Street and Westchester Ave, from July 18st to August 4th, announcing Port Chester Fest.

We plan to present six (6) performances on the Showmobile and three (3) dance performances in front on the stage. Additionally, there will six (6) family-friendly art workshops at the event. As a partner in this event, the Village Logo will appear as a sponsor on all outreach and marketing materials relating to this event. This includes thousands of flyers, our website, posters, the event program, t-shirts, and more. We are most grateful for what you provided last year and look forward to working with you in the future.

Sincerely,

Daniel Lipka
 Executive Director